

Genesis Series
Water-to-Water
Heat Pumps

Revision: 10 June, 2008S



GENESIS WATER-TO-WATER (GSW) SERIES

Table of Contents

Model Nomenclature	3	Unit Starting & Operating Conditions	16
General Information	4	Piping System Cleaning & Flushing Procedure	16
Installation	5	Unit & System Checkout	17
Piping Installation	5	Unit Start-Up Procedure	18
Load Plumbing Installation	6	Preventive Maintenance	19
Water-Loop Heat Pump Application	7	Revision History	20
Ground-Water Heat Pump Application	8		
Water Quality Standards	9		
Ground-Loop Heat Pump Application	10		
Electrical - Power Wiring	12		
Electrical - Low Voltage	14		

Model Nomenclature

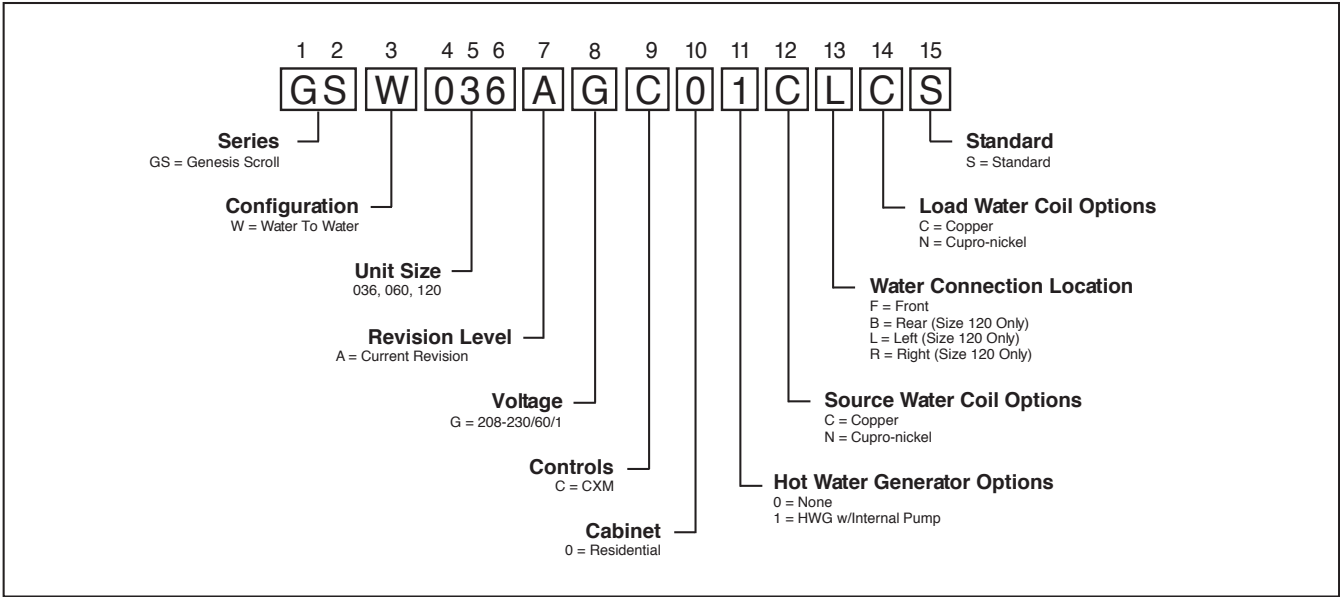

Rev.: 02/27/06D

General Information

Inspection

Upon receipt of the equipment, carefully check the shipment against the bill of lading. Make sure all units have been received. Inspect the carton or crating of each unit, and inspect each unit for damage. Assure the carrier makes proper notation of any shortages or damage on all copies of the freight bill and completes a common carrier inspection report. Concealed damage not discovered during unloading must be reported to the carrier within 15 days of receipt of shipment. **If not filed within 15 days, the freight company can deny the claim without recourse. Note: It is the responsibility of the purchaser to file all necessary claims with the carrier.** Notify the ClimateMaster Traffic Department of all damage within fifteen (15) days of shipment.

Storage

Equipment should be stored in its shipping carton in a clean, dry area. Store units in an upright position at all times. Stack units a maximum of 3 units high.

Unit Protection

Cover units on the job site with either shipping cartons, vinyl film, or an equivalent protective covering. Cap the open ends of pipes stored on the job site. In areas where painting, plastering, and/or spraying has not been completed, all due precautions must be taken to avoid physical damage to the units and contamination by foreign material. Physical damage and contamination may prevent proper start-up and may result in costly equipment clean-up.

Examine all pipes, fittings, and valves before installing any of the system components. Remove any dirt or trash found in or on these components.

Pre-Installation

Installation, Operation, and Maintenance instructions are provided with each unit. The installation site chosen should include adequate service clearance around the unit. Before unit start-up, read all manuals and become familiar with the unit and its operation. Thoroughly check the system before operation.

Prepare units for installation as follows:

1. Compare the electrical data on the unit nameplate with ordering and shipping information to verify that the correct unit has been shipped.
2. Keep the cabinet covered with the shipping carton until installation is complete and all plastering, painting, etc. is finished.
3. Verify refrigerant tubing is free of kinks or dents and that it does not touch other unit components.

4. Inspect all electrical connections. Connections must be clean and tight at the terminals.
5. Loosen compressor bolts on units equipped with compressor spring vibration isolation until the compressor rides freely on the springs. Remove shipping restraints.
6. Locate and verify any HWG or other accessory kit located in the compressor section.

⚠ WARNING! ⚠

DO NOT store or install units in corrosive environments or in locations subject to temperature or humidity extremes (e.g., attics, garages, rooftops, etc.) Corrosive conditions and high temperature or humidity can significantly reduce performance, reliability, and service life. Always move units in an upright position. Tilting units on their sides may cause equipment damage.

⚠ WARNING! ⚠

To avoid the release of refrigerant into the atmosphere, the refrigerant circuit of this unit must be serviced only by technicians who meet local, state, and federal proficiency requirements.

All refrigerant discharged from this unit must be recovered WITHOUT EXCEPTION. Technicians must follow industry accepted guidelines and all local, state, and federal statutes for the recovery and disposal of refrigerants.

⚠ CAUTION! ⚠

If a compressor is removed from this unit, system refrigerant circuit oil will remain in the compressor. To avoid leakage of compressor oil, the refrigerant lines of the compressor must be sealed after it is removed.

Installation

GSW Unit Location

These units are not designed for outdoor installation. Locate the unit in an INDOOR area that allows enough space for service personnel to perform typical maintenance or repairs.

The installation of water source heat pump units and all associated components, parts and accessories which make up the installation shall be in accordance with the regulations of ALL authorities having jurisdiction and MUST conform to all applicable codes. It is the responsibility of the Installing Contractor to determine and comply with ALL applicable codes and regulations.

Locate the unit in an indoor area that allows easy removal of access panels, and has enough space for service personnel

to perform maintenance or repair. Provide sufficient room to make water and electrical connections. Any access panel screws that would be difficult to remove after the unit is installed should be removed prior to setting the unit. These units are not approved for outdoor installation and, therefore, must be installed inside the structure being conditioned. Do not locate in areas where ambient conditions are not maintained within 40-100°F and up to 75% relative humidity.

PIPING INSTALLATION

Installation of Supply and Return Piping

Follow these piping guidelines.

1. Install a drain valve at the base of each supply and return riser to facilitate system flushing.
2. Install shut-off/balancing valves and unions at each unit to permit unit removal for servicing.
3. Place strainers at the inlet of each system circulating pump.
4. Select the proper hose length to allow slack between connection points. Hoses may vary in length by +2% to -4% under pressure.
5. Refer to Table 1. Do not exceed the minimum bend radius for the hose selected. Exceeding the minimum bend radius may cause the hose to collapse which reduces water flow rate. Install an angle adapter to avoid sharp bends in the hose when the radius falls below the required minimum.

Insulation is not required on loop water piping except where the piping runs through unheated areas or outside the building or when the loop water temperature is below the minimum expected dew point of the pipe ambient.

Insulation is required if loop water temperature drops below the dew point.

⚠ WARNING! ⚠

Do not bend or kink supply lines or hoses.

Figure 1: Supply/Return Hose Kit

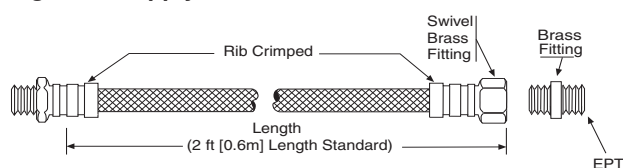

Pipe joint compound is not necessary when Teflon threaded tape is pre-applied to hose assemblies or when flared-end connections are used. If pipe joint compound is preferred, use compound only in small amounts on the male pipe threads of the fitting adapters. Prevent sealant from reaching the flared surfaces of the joint.

Note: When anti-freeze is used in the loop, assure that it is compatible with Teflon tape or pipe joint compound employed.

Maximum allowable torque for brass fittings is 30 foot-pounds. If a torque wrench is not available, tighten finger-tight plus one quarter turn. Tighten steel fittings as necessary.

⚠ CAUTION! ⚠

Piping must comply with all applicable codes.

Table 1: Metal Hose Minimum Bend Radii

Hose Diameter	Minimum Bend Radius
1/2" [12.7mm]	2-1/2" [63.5mm]
3/4" [19.1mm]	4" [101.6mm]
1" [25.4mm]	5-1/2" [139.7mm]
1-1/4" [31.8mm]	6-3/4" [171.5mm]

Piping Installation

Optional pressure-rated hose assemblies designed specifically for use with ClimateMaster units are available. Similar hoses can be obtained from alternate suppliers. Supply and return hoses are fitted with swivel-joint fittings at one end to prevent kinking during installation.

Refer to Figure 1 for an illustration of a Supply/Return Hose Kit. Male adapters secure hose assemblies to the unit and risers. Install hose assemblies properly and check them regularly to avoid system failure and reduced service life.

⚠ CAUTION! ⚠

Corrosive system water requires corrosion resistant fittings and hoses and possibly water treatment.

LOAD PLUMBING INSTALLATION

GSW Unit Load Plumbing

The applications are too varied to describe in this document, however some basic guidelines will be presented. Much of the discussions on water loop applications would be valid for the load plumbing discussion as well. All plumbing should conform to local codes and consider the following:

Wide temperature variation applications such as heating/cooling coils

- Employ piping materials that are rated for the maximum temperature and pressure combination. This excludes PVC for most heating applications.
- Insure load water flow in high temperature heating applications is at least 3 gpm per ton to improve performance and reduce nuisance high pressure faults.
- Should NOT employ plastic to metal threaded joints
- Utilize a pressure tank and air separator vent system to equalize pressure and remove air..

Swimming Pool Hot Tub Applications

- Load coax material should always be, at a minimum cupro-nickel in chlorine/bromine fluid applications.

Potable Water Applications

- Load coax material should always be vented double walled for use in potable water systems.
- Insure load water flow in high temperature heating applications is at least 3 gpm per ton to improve performance and reduce nuisance high pressure faults.

Water-Loop Heat Pump Applications

Commercial systems typically include a number of units plumbed to a common piping system. Any unit plumbing maintenance work can introduce air into the piping system, therefore air elimination equipment is a major portion of the mechanical room plumbing. In piping systems expected to utilize water temperatures below 50°F [10°C], 1/2" closed cell insulation is required on all piping surfaces to eliminate condensation. Metal to plastic threaded joints should never be employed due to their tendency to leak over time. All non-distributor class units include a low temperature-soldered bracket-supported FPT water connection. Teflon tape thread sealant is recommended to minimize internal fouling of the heat exchanger. Do not overtighten connections and route piping so as not to interfere with service or maintenance access. Hose kits are available from ClimateMaster in different configurations as shown in Figure 2 for connection between the GSW Series and the piping system. The hose kits include shut off valves, P/T plugs for performance measurement, high pressure stainless steel braid hose, "Y" type strainer with blowdown valve, and "J" type swivel connection. Balancing valves to facilitate the balancing of the system, and an external low pressure drop solenoid valve for use in variable speed pumping systems, may also be included in the hose kit. The piping system should be flushed to remove dirt,

piping chips, and other foreign material prior to operation. See Piping System Cleaning and Flushing Procedures. The flow rate is usually set between 2.25 and 3 gpm per ton of cooling capacity. ClimateMaster recommends 2.5 gpm per ton for most applications of water loop heat pumps. To insure proper maintenance and servicing, P/T ports are imperative for temperature and flow verification, as well as performance checks.

Cooling Tower/Boiler Systems typically utilize a common loop maintained at 60-90°F [15.6 - 32.2°C]. The use of a closed circuit evaporative cooling tower with a secondary heat exchanger between the tower and the water loop is recommended. If an open type cooling tower is used continuously, chemical treatment and filtering will be necessary.

Low Water Temperature Cutout Setting

CXM or DXM Control:

When an antifreeze is selected, the FP1 jumper (JW3) should be clipped to select the low temperature (Antifreeze 13°F [-10.6]) setpoint to avoid nuisance faults. See Low Water Temperature Cutout Selection.

Figure 2: Typical Water Loop Application. GSW036-060 shown GSW120 is similar.

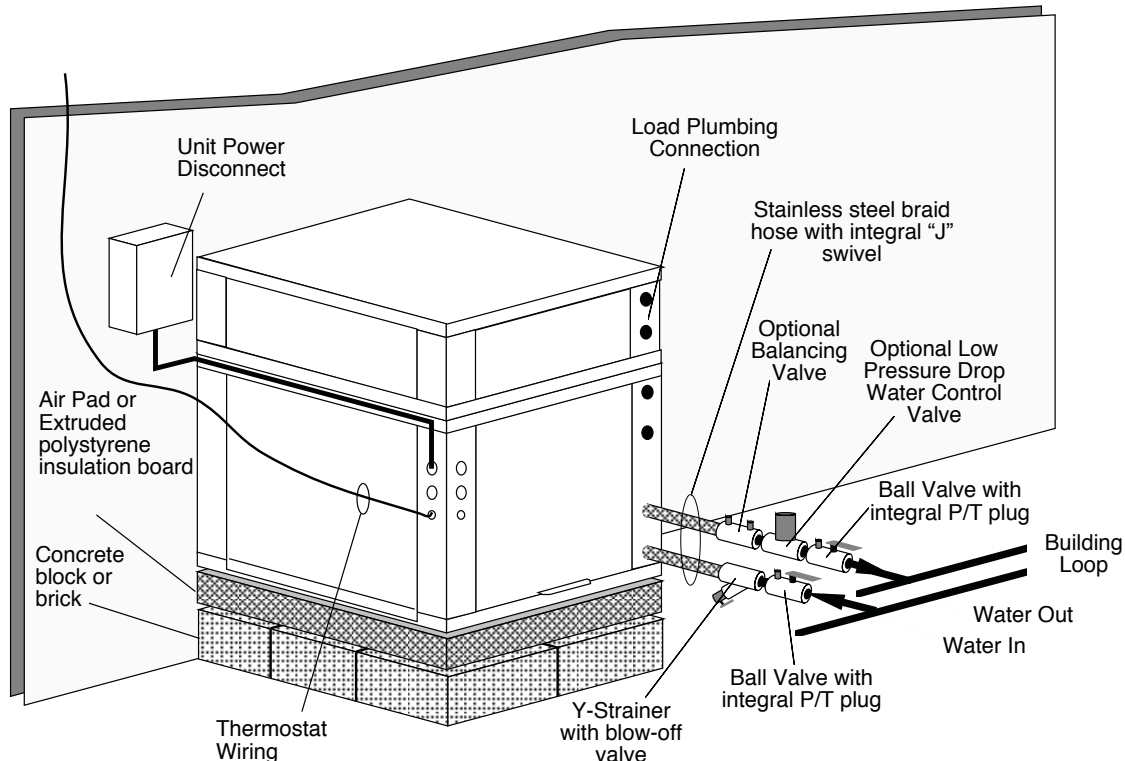

Ground-Water Heat Pump Systems

Typical open loop piping is shown in Figure 3. Shut off valves should be included in case of servicing. Boiler drains or other valves should be 'tee'd' into the line to allow acid flushing of just the heat exchanger. Pressure temperature plugs should be used so that flow and temperature can be measured. The water freeze-stat should be wired. Piping materials should be limited to PVC SCH80 or copper. **Due to the pressure and temperature extremes, PVC SCH40 is not recommended.** Water quantity should be plentiful and of good quality. Consult Table 2 for water quality guidelines. The unit can be ordered with either a copper or cupro-nickel water heat exchanger. Copper is recommended for closed loop systems and open loop ground water systems that are not high in mineral content or corrosiveness. In conditions anticipating heavy scale formation or in brackish water, a cupro-nickel heat exchanger is recommended. In ground water situations where scaling could be heavy or where biological growth such as iron bacteria will be present, a closed loop system is recommended. Heat exchanger coils may over time lose heat exchange capabilities due to a build up of mineral deposits inside. These can be cleaned only by a qualified service mechanic as acid and special pumping equipment are required.

Desuperheater coils can likewise become scaled and possibly plugged. In areas with extremely hard water, the homeowner should be informed that the heat exchanger may require occasional acid flushing.

Expansion Tank and Pump

Use a closed, bladder-type expansion tank to minimize mineral formation due to air exposure. The expansion tank should be sized to handle at least one minute run time of the pump to prevent premature pump failure using its drawdown capacity rating. The pump should be sized to the home's domestic water load (5-9 gpm) plus the heat pump water load. Discharge water from the unit is not contaminated in any manner and can be disposed of in various ways depending on local building codes; i.e. recharge well, storm sewer, drain field, adjacent stream or pond, etc. Most local codes forbid the use of sanitary sewer for disposal. Consult your local building and zoning department to assure compliance in your area.

Water Control Valve

Note the placement of the water control valve. Always maintain water pressure in the heat exchanger by placing water control valves at the outlet of the unit to prevent mineral precipitation. Pilot operated or Taco slow closing valve's solenoid valves are recommended to reduce water hammer. If water hammer persists, a mini-expansion tank can be mounted on the piping to help absorb the excess hammer shock. Insure that the total 'VA' draw of the valve can be

supplied by the unit transformer. For instance the Taco slow closing valve can draw up to 35VA. This can overload smaller 40 or 50 VA transformers depending on the other controls employed. A typical pilot operated solenoid valve draws approximately 15VA. Note the special wiring diagram of the AVM valve (Figure 9).

Flow Regulation

Flow regulation can be accomplished by two methods. First, most water control valves have a built in flow adjustment. By measuring the pressure drop through the unit heat exchanger, flow rate can be determined and compared to Table 7. Since the pressure is constantly varying, two pressure gauges might be needed. Simply adjust the water control valve until the desired flow of 1.5 to 2 gpm per ton is achieved. Secondly, a flow control device may be installed. The devices are typically an orifice of plastic material that is designed to allow a specified flow rate. These are mounted on the outlet of the water control valve. On occasion, these valves can produce a velocity noise that can be reduced by applying some back pressure. This is accomplished by slightly closing the leaving isolation valve of the well water setup.

Low Temperature Cutout

The water low temperature cutout setpoint should be activated to avoid freeze damage to the unit. Consult the low temperature cutout section of the controls description for instructions.

⚠ CAUTION! ⚠

CAUTION! Many units installed with a factory or field supplied manual or electric shut-off valve. **DAMAGE WILL OCCUR** if shut-off valve is **closed** during unit operation. A high pressure switch must be installed on the heat pump side of any field provided shut-off valves and connected to the heat pump controls in series with the built-in refrigerant circuit high pressure switch to disable compressor operation if water pressure exceeds pressure switch setting. The field installed high pressure switch shall have a cut-out pressure of 235 psig and a cut-in pressure of 190 psig. This pressure switch can be ordered from ClimateMaster with a 1/4" internal flare connection as part number 39B0005N01.

⚠ CAUTION! ⚠

CAUTION! Refrigerant pressure activated water regulating valves should never be used with ClimateMaster equipment.

Ground-Water Heat Pump Systems

Figure 3: Typical Open Loop/ Well Application. GSW036-060 shown GSW120 is similar.

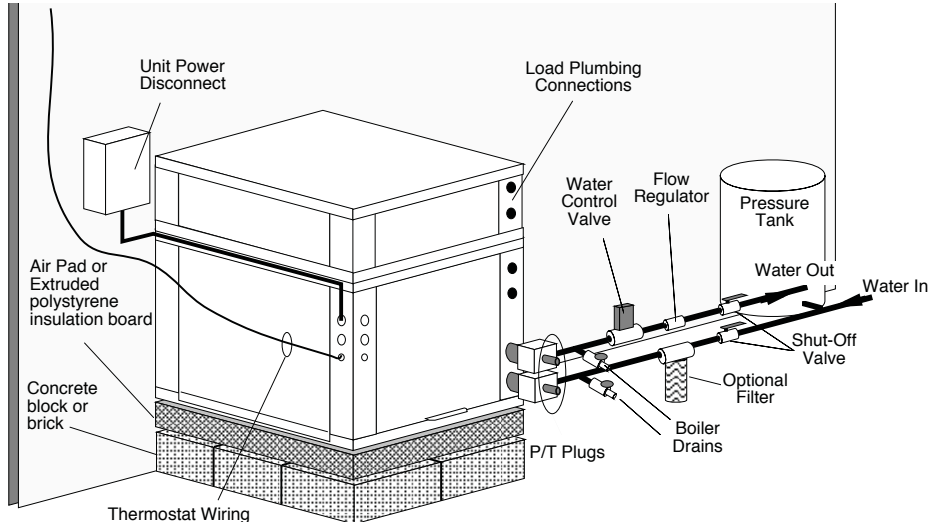

Table 2: Water Quality Standards

Water Quality Parameter	HX Material	Closed Recirculating	Open Loop and Recirculating Well		
Scaling Potential - Primary Measurement					
Above the given limits, scaling is likely to occur. Scaling indexes should be calculated using the limits below					
pH/Calcium Hardness Method	All	-	pH < 7.5 and Ca Hardness <100ppm		
Index Limits for Probable Scaling Situations - (Operation outside these limits is not recommended)					
Scaling indexes should be calculated at 150°F [66°C] for direct use and HWG applications, and at 90°F [32°C] for indirect HX use. A monitoring plan should be implemented.					
Ryznar Stability Index	All	-	6.0 - 7.5 If >7.5 minimize steel pipe use.		
Langelier Saturation Index	All	-	-0.5 to +0.5 If <-0.5 minimize steel pipe use. Based upon 150°F [66°C] HWG and Direct well, 85°F [29°C] Indirect Well HX		
Iron Fouling					
Iron Fe ²⁺ (Ferrous) (Bacterial Iron potential)	All	-	<0.2 ppm (Ferrous) If Fe ²⁺ (ferrous)>0.2 ppm with pH 6 - 8, O2<5 ppm check for iron bacteria		
Iron Fouling	All	-	<0.5 ppm of Oxygen Above this level deposition will occur.		
Corrosion Prevention					
pH	All	6 - 8.5 Monitor/treat as needed	6 - 8.5 Minimize steel pipe below 7 and no open tanks with pH <8		
Hydrogen Sulfide (H ₂ S)	All	-	<0.5 ppm At H ₂ S>0.2 ppm, avoid use of copper and copper nickel piping or HX's. Rotten egg smell appears at 0.5 ppm level. Copper alloy (bronze or brass) cast components are OK to <0.5 ppm.		
Ammonia ion as hydroxide, chloride, nitrate and sulfate compounds	All	-	<0.5 ppm		
Maximum Chloride Levels	Maximum Allowable at maximum water temperature.				
		50°F (10°C)	75°F (24°C)	100°F (38°C)	
	Copper	-	<20ppm	NR	NR
	CuproNickel	-	<150 ppm	NR	NR
	304 SS	-	<400 ppm	<250 ppm	<150 ppm
316 SS	-	<1000 ppm	<550 ppm	< 375 ppm	
Titanium	-	>1000 ppm	>550 ppm	>375 ppm	
Erosion and Clogging					
Particulate Size and Erosion	All	<10 ppm of particles and a maximum velocity of 6 fps [1.8 m/s] Filtered for maximum 800 micron [800mm, 20 mesh] size.	<10 ppm (<1 ppm "sandfree" for reinjection) of particles and a maximum velocity of 6 fps [1.8 m/s]. Filtered for maximum 800 micron [800mm, 20 mesh] size. Any particulate that is not removed can potentially clog components.		

Notes:
 • Closed Recirculating system is identified by a closed pressurized piping system.
 • Recirculating open wells should observe the open recirculating design considerations.
 • NR - Application not recommended.
 • -/- No design Maximum.

Rev.: 01/21/09B

Ground-Loop Heat Pump Applications

Piping Installation

The typical closed loop ground source system is shown in Figure 4. All earth loop piping materials should be limited to only polyethylene fusion in inground sections of the loop. Galvanized or steel fitting should not be used at any time due to their tendency to corrode. All plastic to metal threaded fittings should be avoided due to their potential to leak in earth coupled applications and a flanged fitting substituted. P/T plugs should be used so that flow can be measured using the pressure drop of the unit heat exchanger in lieu of other flow measurement means. Earth loop temperatures can range between 25-110°F [-3.9 - 43.3°C] and 2.25 to 3 gpm of flow per ton of cooling capacity is recommended in these applications. Upon completion of the ground loop piping, pressure test the loop to assure a leak free system. Horizontal Systems: test individual loops as installed. Test entire system when all loops are assembled.

Table 3: Approximate Fluid Volume (gal.) per 100' of Pipe

Fluid Volume (gal [liters] per 100' [30 meters] Pipe)		
Pipe	Size	Volume (gal) [liters]
Copper	1"	4.1 [15.3]
	1.25"	6.4 [23.8]
	2.5"	9.2 [34.3]
Rubber Hose	1"	3.9 [14.6]
Polyethylene	3/4" IPS SDR11	2.8 [10.4]
	1" IPS SDR11	4.5 [16.7]
	1.25" IPS SDR11	8.0 [29.8]
	1.5" IPS SDR11	10.9 [40.7]
	2" IPS SDR11	18.0 [67.0]
	1.25" IPS SCH40	8.3 [30.9]
	1.5" IPS SCH40	10.9 [40.7]
	2" IPS SCH40	17.0 [63.4]
Unit Heat Exchanger	Typical	1.0 [3.8]
Flush Cart Tank	10" Dia x 3ft tall [254mm x 91.4cm tall]	10 [37.9]

Vertical U-Bends and Pond Loop Systems: test vertical U-bends and pond loop assemblies prior to installation with a test pressure of at least 100 psi. Either water or air may be used as the testing medium.

Flushing the Earth Loop

Once piping is completed between the unit, flow center and the ground loop (Figure 4), final purging and charging of the loop is needed. A flush cart (at least a 1.5 hp pump) is needed to achieve adequate flow velocity in the loop to purge air and dirt particles from the loop itself. An antifreeze solution is used in most areas to prevent freezing. All air and debris must be removed from the earth loop piping system before operation. Flush the loop with a high volume of water at a high velocity (2 fps in all piping) both directions. The steps below must be followed for proper flushing. Fill loop with water from a garden hose through flush cart before using flush cart pump to ensure an even fill. Once full, do not allow the water level in the flush cart tank to drop below the pump inlet line or air can be pumped back out to the earth loop. Try to maintain a fluid level in the tank above the return tee so that air can not be continuously mixed back into the fluid. 50 psi surges can be used to help purge air pockets by simply shutting off the return valve going into the flush cart reservoir. This 'dead heads' the pump to 50 psi. To dead head the pump until maximum pumping pressure is reached, open the valve back up and a pressure surge will be sent through the loop to help purge air pockets from the piping system. Notice the drop in fluid level in the flush cart tank. **If air is purged from the system, the level will drop only 1-2 inches in a 10" diameter PVC flush tank (about a half gallon) since liquids are incompressible.** If the level drops more than this, flushing should continue since air is still being compressed in the loop fluid. Do this a number of times.

When the fluid level drops less than 1-2" in a 10" diameter tank the flow can be reversed. Finally the dead head test should be checked again for an indication of air in the loop. **This fluid level drop is your only indication of air in the loop.**

Table 4: Antifreeze Percentages by Volume

Type	Minimum Temperature for Low Temperature Protection			
	10°F [-12.2°C]	15°F [-9.4°C]	20°F [-6.7°C]	25°F [-3.9°C]
Methanol	25%	21%	16%	10%
100% USP food grade Propylene Glycol	38%	25%	22%	15%
Ethanol*	29%	25%	20%	14%

* Must not be denatured with any petroleum based product

Ground-Loop Heat Pump Applications

Antifreeze may be added before, during, or after the flushing procedure. However, depending upon which time is chosen, antifreeze could be wasted when emptying the flush cart tank. See antifreeze section for more details. Loop static pressure will fluctuate with the seasons. Pressures will be higher in the winter months than during the cooling season. This fluctuation is normal and should be considered when charging the system initially. Run the unit in either heating or cooling for a number of minutes to condition the loop to a homogenous temperature. This is a good time for tool cleanup, piping insulation etc. Then final flush and pressurize the loop to a static pressure of 40-50 psi (winter) 15-20 psi (summer).

After pressurization, be sure to remove the plug in the end of the Grundfos loop pump motor(s) to allow trapped air to be discharged and to insure the motor housing has been flooded. This is not required for Taco circulators. Insure the loop flow center provides adequate flow through the unit by checking pressure drop across the heat exchanger and comparing it to the figures shown in Table 6.

Antifreeze

In areas where minimum entering loop temperatures drop below 40°F [4.4°C] or where piping will be routed through areas subject to freezing, antifreeze is needed. Alcohols

and glycols are commonly used as antifreezes, however your local territory manager should be consulted for the antifreeze best suited to your area. Freeze protection should be maintained to 15°F [-9.4°C] below the lowest expected entering loop temperature. For example, if 30°F [-1.1°C] is the minimum expected entering loop temperature, the leaving loop temperature would be 25-22°F [-3.9 - -5.6°C] and freeze protection should be at 15°F [-9.4°C] (30°F-15°F=15°F). All alcohols should be premixed and pumped from a reservoir outside of the building when possible or introduced under water level to prevent fuming. Initially calculate the total volume of fluid in the piping system using Table 3. Then use the percentage by volume shown in Table 4 for the amount of antifreeze. Antifreeze concentration should be checked from a well mixed sample using a hydrometer to measure specific gravity.

Low Water Temperature Cut-Out Setting

When an antifreeze is selected the low temperature limit setpoint should be switched to the lower setting to avoid nuisance faults. Consult **Low Water Temperature Cut-Out Setting** in the controls section for more information.

Figure 4: Typical Earth Loop Connection. GSW036-060 shown, GSW120 requires larger pump than AFSC2 please consult the factory.

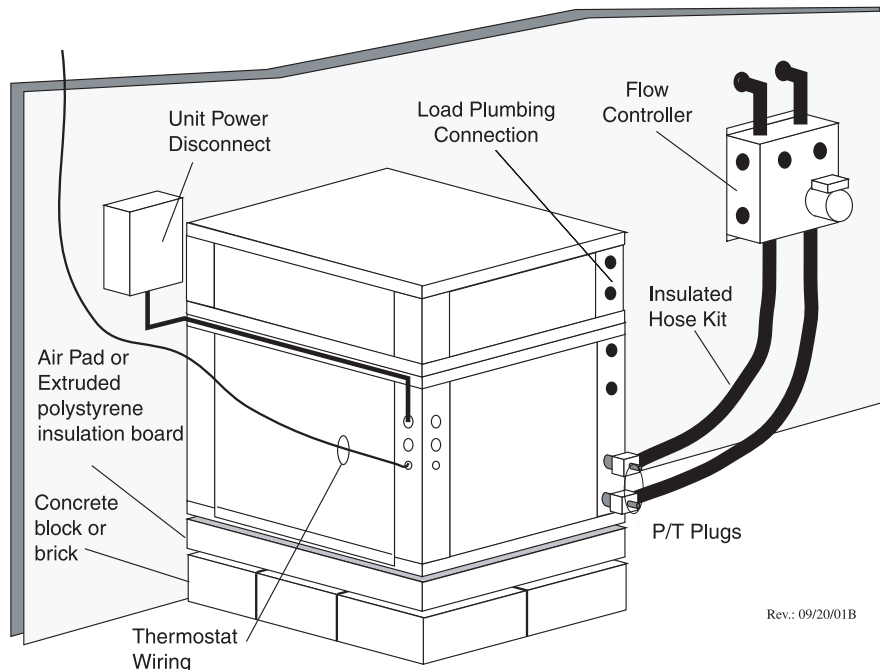

Rev.: 09/20/01B

Electrical - Line Voltage

⚠ WARNING! ⚠

To avoid possible injury or death due to electrical shock, open the power supply disconnect switch and secure it in an open position during installation.

⚠ CAUTION! ⚠

Use only copper conductors for field installed electrical wiring. Unit terminals are not designed to accept other types of conductors.

⚠ WARNING! ⚠

Disconnect electrical power source to prevent injury or death from electrical shock.

General Line Voltage Wiring

Be sure the available power is the same voltage and phase as that shown on the unit serial plate. Line and low voltage wiring must be done in accordance with local codes or the National Electric Code, whichever is applicable.

GSW Power Connection

Line voltage connection is made by connecting the incoming line voltage wires to the “L” side of the contactor or power block as shown in Figures 5a, b and c. Consult Table 5 for correct fuse size.

Table 5: Electrical Data

Model	Voltage Code	Voltage	Min/Max Voltage	Compressor			HWG Pump FLA	Ext Loop Pump FLA	Total Unit FLA	Min Circuit Amps	Max Fuse/HACR
				QTY	RLA	LRA					
GSW036 Residential	G	208-230/60/1	197/254	1	15.0	73.0	0.4	4.0	19.4	23.2	35
GSW036 Commercial	G	208-230/60/1	197/254	1	15.0	73.0	-	-	15.0	18.8	30
	E	265/60/1	239/292	1	14.3	71.0	-	-	14.3	17.9	30
	H	208-230/60/3	197/254	1	10.7	63.0	-	-	10.7	13.4	20
	F	460/60/3	414/506	1	5.0	31.0	-	-	5.0	6.3	15
GSW060 Residential	G	208-230/60/1	197/254	1	28.0	169.0	0.4	4.0	32.4	39.4	60
GSW060 Commercial	G	208-230/60/1	197/254	1	28.0	169.0	-	-	28.0	35.0	60
	H	208-230/60/3	197/254	1	19.3	123.0	-	-	19.3	24.1	40
	F	460/60/3	414/506	1	7.5	49.5	-	-	7.5	9.4	15
	N	575/60/3	518/633	1	6.4	40.0	-	-	6.4	8.0	15
GSW120 Commercial	G	208-230/60/1	197/254	2	28.0	169.0	-	-	56.0	63.0	90
	H	208-230/60/3	197/254	2	19.3	123.0	-	-	38.6	43.4	60
	F	460/60/3	414/506	2	7.5	49.5	-	-	15.0	16.9	20
	N	575/60/3	518/633	2	6.4	40.0	-	-	12.8	14.4	20

HACR circuit breaker in USA only
 Residential units come standard with 75VA transformer, HWG pump, and HWG connections

Electrical - Line Voltage

Figure 5a: GSW036-060 Series Line Voltage Field Wiring Distributor Class

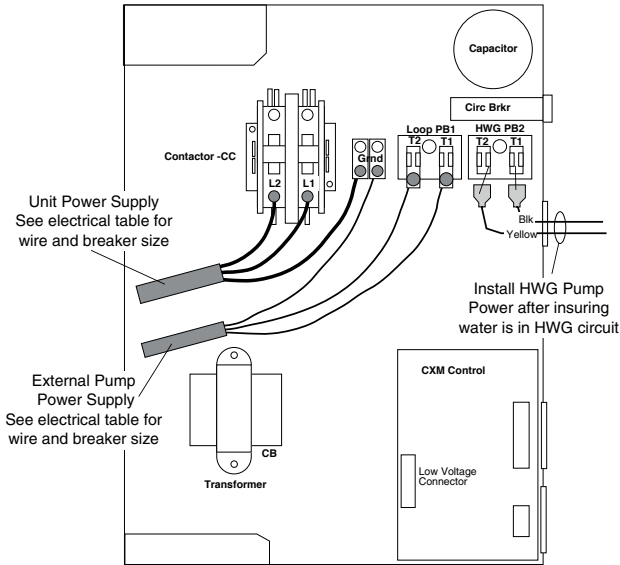

Rev.: 09/20/01

All field installed wiring, including electrical ground, must comply with the National Electrical Code as well as all applicable local codes.

Refer to the unit wiring diagrams for fuse sizes and a schematic of the field connections which must be made by the installing (or electrical) contractor.

Consult the unit wiring diagram located on the inside of the compressor access panel to ensure proper electrical hookup.

All final electrical connections must be made with a length of flexible conduit to minimize vibration and sound transmission to the building.

208 Volt Operation

All 208-240 Volt units are factory wired for 208 Volt. The transformers may be switched to 240V operation as illustrated on the wiring diagram. By switching the Red (240V) and the Orange (208V) at the contactor terminal L2.

Figure 5b: GSW036-060 Series Line Voltage Field Wiring Commercial Class (3 phase shown)

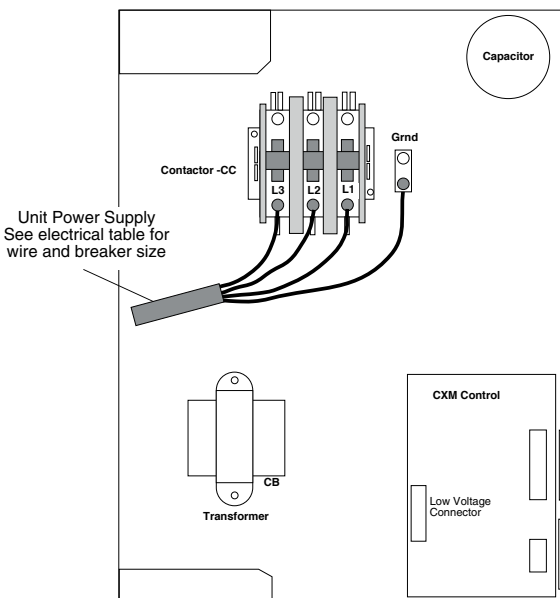

Rev.: 09/20/01

Figure 5c: GSW120 Series Line Voltage Field Wiring Commercial Class

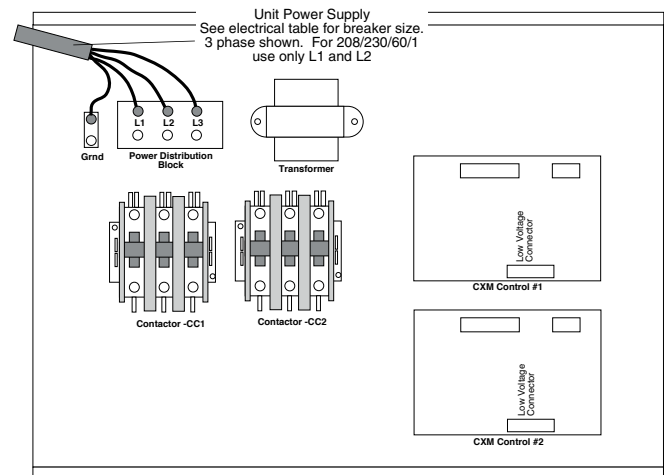

Rev.: 10/04/01 B

Electrical - Low Voltage

Thermostat Connections

The aquastat/thermostat should be wired directly to the CXM/DXM board as shown in Figure 6a for GSW036-060 and Figure 6b for the GSW120. Note the GSW second stage is wired directly to the CXM #2.

Figure 6a. GSW036-060 Low Voltage Field Wiring (CXM shown)

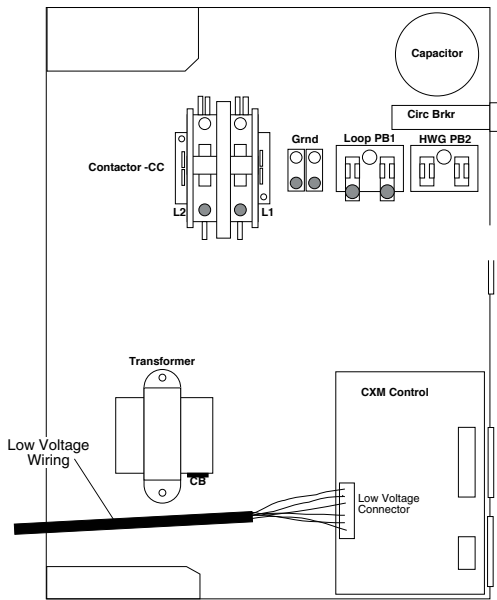

Rev.: 09/20/01B

Low Water Temperature Cutout - FP1

The CXM/DXM control allows the field selection of source fluid low temperature cutout points. The factory setting of FP1 is set for water (30°F [-1.1°C]). In cold temperature applications jumper JW3 (FP1- antifreeze 10°F [-12.2°C]) should be clipped as shown in Figure 7 to change the setting to 10°F [-12.2°C], a more suitable temperature when using antifreezes. It should be noted that the extended range option should be specified to operate the GSW Series at entering water temperatures below 60°F [15.6°C].

Figure 7: Changing FP1-Low Water Temperature Cutout Setpoint

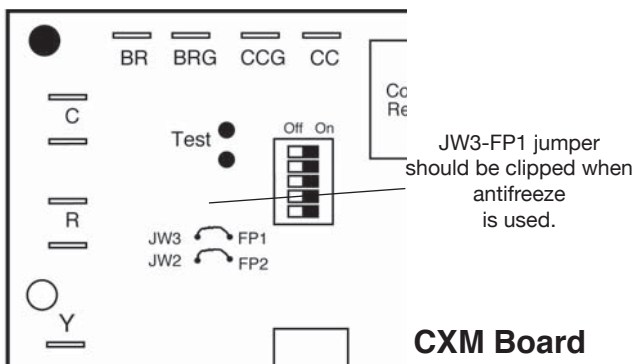

CXM Board

Figure 6b: GSW120 Low Voltage Field Wiring (CXM shown)

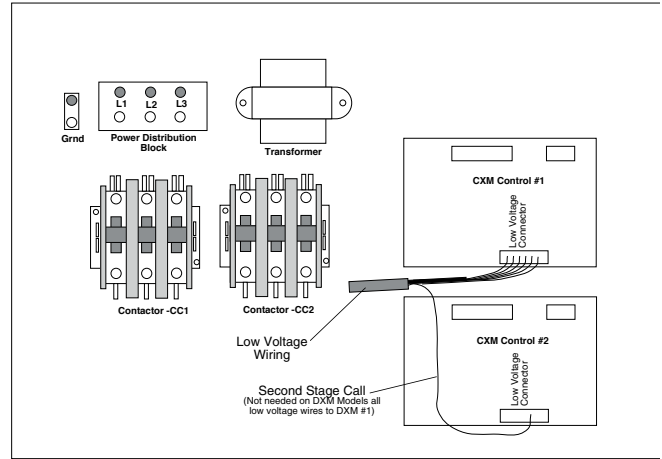

Rev.: 10/04/01 B

Accessory Connections

A terminal paralleling the compressor contactor coil has been provided on the CXM/DXM control of the GSW line. "A" has been provided to control accessory devices, such as water valves, electronic air cleaners, humidifiers, etc. **Note: This terminal should be used only with 24 Volt signals and not line voltage signals.** This signal operates with the compressor contactor. See Figure 8 or the wiring schematic for details.

Figure 8: Accessory Wiring Terminal Strip

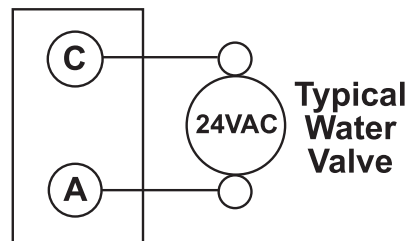

Water Solenoid Valves

Figure 9 illustrates a typical slow closing water control valve wiring. A slow closing valve may be required to prevent water hammer. When using an AVM -Taco Slow Closing valves on GSW Series equipment Figure 9 wiring should be utilized. The valve takes approximately 60 seconds to open (very little water will flow before 45 seconds) and it activates the compressor only after the valve is completely opened (by closing its end switch). Only relay or triac based electronic thermostats should be used with the AVM valve. When wired as shown, the valve will operate properly with the following notations:

Electrical - Low Voltage

1. The valve will remain open during a unit lockout.
2. The valve will draw approximately 25-35 VA through the "Y" signal of the thermostat. **Note: This can overheat the anticipators of electromechanical thermostats.** Therefore only relay or triac based thermostats should be used.

Figure 9: Well Water AMV Valve Wiring

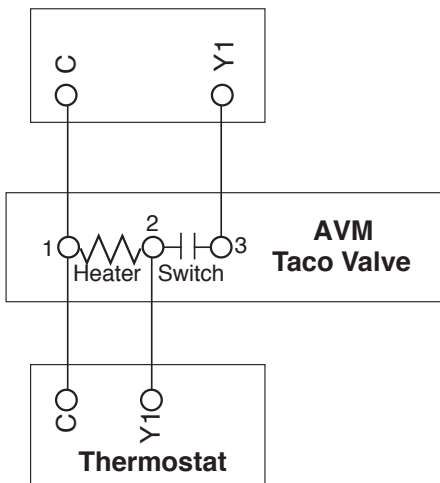

⚠ CAUTION! ⚠

CAUTION! Many units installed with a factory or field supplied manual or electric shut-off valve. **DAMAGE WILL OCCUR** if shut-off valve is **closed** during unit operation. A high pressure switch must be installed on the heat pump side of any field provided shut-off valves and connected to the heat pump controls in series with the built-in refrigerant circuit high pressure switch to disable compressor operation if water pressure exceeds pressure switch setting. The field installed high pressure switch shall have a cut-out pressure of 235 psig and a cut-in pressure of 190 psig. This pressure switch can be ordered from ClimateMaster with a 1/4" internal flare connection as part number 39B0005N01.

⚠ CAUTION! ⚠

CAUTION! Refrigerant pressure activated water regulating valves should never be used with ClimateMaster equipment.

Unit Starting & Operating Conditions

Operating Limits

Environment – This unit is designed for indoor installation only.

Power Supply – A voltage variation of +/- 10% of nameplate utilization voltage is acceptable.

Starting Conditions

GSW Units – Units start and operate in an ambient of 45°F [7.2°C] with entering air at 50°F [10°C], entering water at 30°F [-1.1°C] and both air and water at the stated flow rates of 3 gpm per ton for initial winter start-up.

Notes:

- These are not normal or continuous operating conditions. It is assumed that winter start-up is to bring the building space up to occupancy temperatures.
- Voltage utilization range complies with ARI Standard 110.

Determination of operating limits is dependent primarily upon three factors: 1) entering load temperature. 2) entering source temperature and 3) ambient temperature. When any

one of these factors is at minimum or maximum levels, the other two factors should be at normal levels to ensure proper unit operation.

Extreme variations in temperature and humidity and corrosive water will adversely affect unit performance, reliability, and service life.

Table 6: Operating Limits

Source Side Water Limits	Cooling	Heating
Minimum Entering Water	50°F [10°C]	20°F [-6.6°C]
Normal Entering Water	85°F [29.4°C]	60°F [15.6°C]
Maximum Entering Water	110°F [43.3°C]	70°F [21.1°C]
Load Side Water Limits		
Minimum Entering Water	50°F [10°C]	60°F [15.6°C]
Normal Entering Water	60°F [15.6°C]	100°F [37.8°C]
Maximum Entering Water	90°F [32.2°C]	120°F [48.9°C]

PIPING SYSTEM CLEANING & FLUSHING

Cleaning and flushing of the WLHP piping system is the single most important step to ensure proper start-up and continued efficient operation of the system.

Follow the instructions below to properly clean and flush the system:

- Verify electrical power to the unit is disconnected.
- Install the system with the supply hose connected directly to the return riser valve. Use a single length of flexible hose.
- Open all air vents. Fill the system with the water. DO NOT allow system to overflow. Bleed all air from the system. Pressurize and check the system for leaks and repair appropriately.
- Verify all strainers are in place. Start the pumps, and systematically check each vent to ensure all air is bled from the system.
- Verify make-up water is available. Adjust make-up water appropriately to replace the air which was bled from the system. Check and adjust the water/air level in the expansion tank.
- Set the boiler to raise the loop temperature to approximately 85°F [29.4°C]. Open the a drain at the lowest point in the system. Adjust the make-up water replacement rate to equal the rate of bleed.
- Refill the system and add trisodium phosphate in a proportion of approximately one pound per 150 gallons of water (or other equivalent approved cleaning agent). Reset the boiler to raise the loop temperature to about

⚠ CAUTION! ⚠

To avoid possible damage to a plastic (PVC) piping system, do not allow temperatures to exceed 110°F [43.3°C].

- 100°F [37.8°C]. Circulate the solution for a minimum of 8 to 24 hours. At the end of this period, shut off the circulating pump and drain the solution. Repeat system cleaning if desired.
- When the cleaning process is complete, remove the short-circuited hoses. Reconnect the hoses to the proper supply, and return the connections to each of the units. Refill the system and bleed off all air.
- Test the system pH with litmus paper. The system water should be slightly alkaline (pH 7.5-8.5). Add chemicals, as appropriate, to maintain acidity levels.
- When the system is successfully cleaned, flushed, refilled and bled, check the main system panels, safety cutouts and alarms. Set the controls to properly maintain loop temperatures.

⚠ CAUTION! ⚠

DO NOT use 'stop leak' or any similar chemical agent in this system. Addition of these chemicals to the loop water will foul the system and inhibit unit operation.

Unit & System Checkout

BEFORE POWERING SYSTEM, please check the following:

⚠ WARNING! ⚠

Verify ALL water controls are open and allow water flow prior to engaging the compressor. Freezing of the coax or water lines can permanently damage the heat pump.

UNIT CHECKOUT

- ❑ **Balancing/Shutoff Valves:** Ensure all isolation valves are open, water control valves wired and open or coax may freeze and burst.
- ❑ **Line Voltage and Wiring:** Ensure Voltage is within an acceptable range for the unit and wiring and fuses/breakers are properly sized. Low voltage wiring is complete.
- ❑ **Unit Control Transformer:** Ensure transformer has properly selected control voltage tap. 208-230V units are factory wired for 208V operation unless specified otherwise.
- ❑ **Entering Water:** Ensure entering water temperatures are within operating limits of Table 6.
- ❑ **Low Water Temperature Cutout:** Verify low water temperature cut-out on CXM/DXM is properly set.
- ❑ **Water Flow Balancing:** Verify inlet and outlet water temperatures on both Load and source are recorded for each heat pump upon startup. This check can eliminate nuisance trip outs and high velocity water flows that can erode heat exchangers.
- ❑ **Unit Controls:** Verify CXM or DXM field selection options are proper and complete.

SYSTEM CHECKOUT

- ❑ **System Water Temperature:** Check load and source water temperature for proper range and also verify heating and cooling setpoints for proper operation.
- ❑ **System pH:** System water pH is 7.5 - 8.5. Proper pH promotes longevity of hoses and fittings.

- ❑ **System Flushing:** Verify all hoses are connected end to end when flushing to ensure debris bypasses unit heat exchanger and water valves etc. Water used in the system must be potable quality initially and clean of dirt, piping slag, and strong chemical cleaning agents. Verify all air is purged from the system. Air in the system can cause poor operation or system corrosion.
- ❑ **Cooling Tower/Boiler:** Check equipment for proper setpoints and operation.
- ❑ **Standby Pumps:** Verify the standby pump is properly installed and in operating condition.
- ❑ **System Controls:** Verify system controls function and operate in the proper sequence.
- ❑ **Low Water Temperature Cutout:** Verify low water temperature cut-out controls are provided for the outdoor portion of the loop or operating problems will occur.
- ❑ **System Control Center:** Verify control center and alarm panel for proper setpoints and operation.
- ❑ **Miscellaneous:** Note any questionable aspects of the installation.

⚠ WARNING! ⚠

To avoid equipment damage, DO NOT leave system filled in a building without heat during the winter unless anti-freeze is added to system water. Condenser coils never fully drain by themselves and will freeze unless winterized with antifreeze.

Figure 10: Test Mode Pins

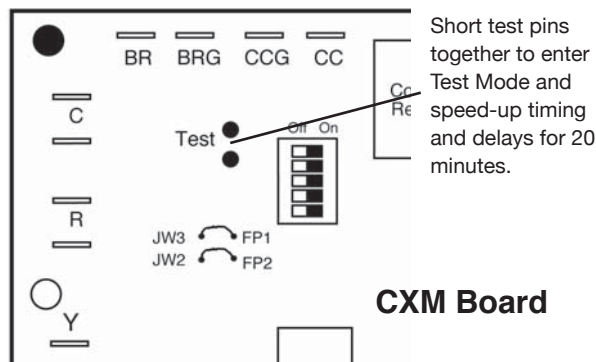

Unit Start-Up Procedure

⚠ WARNING! ⚠

When the disconnect switch is closed, high voltage is present in some areas of the electrical panel. Exercise caution when working with energized equipment.

1. Adjust all valves to their full open position. Turn on the line power to all heat pump units.
2. Operate each unit in the cooling cycle. Loop water temperature entering the heat pumps should be between 70°F [21.1°C] and 110°F [43.3°C].
3. Operate each heat pump in the heating cycle immediately after checking cooling cycle operation. A time delay will prevent the compressor from re-starting for approximately five (5) minutes..
4. Establish a permanent operating record by logging the unit operating conditions at initial start-up for each unit.

5. If a unit fails to operate, conduct the following checks:
 - a. Check the voltage and current. They should comply with the electrical specifications described on the unit nameplate.
 - b. Look for wiring errors. Check for loose terminal screws where wire connections have been made on both the line and low-voltage terminal boards.
 - c. Check the supply and return piping. They must be properly connected to the inlet and outlet connections on the unit.
 - d. If the checks described above fail to reveal the problem and the unit still will not operate, contact a trained service technician to ensure proper diagnosis and repair of the equipment.

Note: Units have a five minute time delay in the control circuit that can be bypassed on the CXM PCB as shown below in Figure 10. See controls description for detailed features of the control.

⚠ WARNING! ⚠

Verify ALL water controls are open and allow water flow prior to engaging the compressor. Freezing of the coax or water lines can permanently damage the heat pump.

Table 7: Coax Water Pressure Drop

Model	GPM	Pressure Drop			
		30°F	50°F	70°F	90°F
Source/Outdoor Coax					
036	5.0	4.2	2.6	2.3	1.8
	7.0	5.8	4.1	4.1	3.1
	9.0	8.4	6.0	5.5	4.9
060	7.5	3.1	2.2	1.9	1.5
	11.3	5.0	4.0	3.6	3.1
	15.0	7.4	6.1	5.5	5.0
120	15.0	4.3	3.1	2.7	2.1
	22.6	7.0	5.6	5.0	4.3
	30.0	10.3	8.5	7.7	7.0
Load/Indoor Coax					
036	5.0		2.3	1.6	1.3
	7.0		4.1	2.9	2.6
	9.0		5.3	4.6	4.3
060	7.5		1.9	1.4	1.1
	11.3		3.4	2.9	2.2
	15.0		5.6	4.6	3.9
120	15.0		2.6	2.0	1.6
	22.6		4.8	3.9	3.1
	30.0		7.8	6.4	5.3

Table 8: Water Temperature Change Through Heat Exchanger

Water Flow, gpm [l/m]	Rise, Cooling °F, [°C]	Drop, Heating °F, [°C]
For Closed Loop: Ground Source or Closed Loop Systems at 3 gpm per ton [3.9 l/m per kW]	9 - 12 [5 - 6.7]	4 - 8 [2.2 - 4.4]
For Open Loop: Ground Water Systems at 1.5 gpm per ton [2.0 l/m per kW]	20 - 26 [11.1 - 14.4]	10 - 17 [5.6 - 9.4]

CXM/DXM Safety Control Reset

Lockout - In Lockout mode, the Status LED will begin fast flashing. The compressor relay is turned off immediately. Lockout mode can be soft reset via the thermostat "Y" input or can be hard reset via the disconnect. The last fault causing the lockout will be stored in memory and can be viewed by going into test mode.

Fault Retry - In Fault Retry mode, the Status LED begins slow flashing to signal that the control is trying to recover from a fault input. The CXM control will stage off the outputs and then "try again" to satisfy the thermostat "Y" input call. Once the thermostat input calls are satisfied, the control will continue on as if no fault occurred. If 3 consecutive faults occur without satisfying the thermostat "Y" input call, then the control will go to Lockout mode. The last fault causing the lockout will be stored in memory and can be viewed by going into test mode.

Consult the CXM and DXM AOM for complete descriptions.

Preventive Maintenance

Water Coil Maintenance

(Direct Ground Water Applications Only)

If the installation is performed in an area with a known high mineral content (125 P.P.M. or greater) in the water, it is best to establish with the owner a periodic maintenance schedule so the coil can be checked regularly. Consult the well water applications section of this manual for a more detailed water coil material selection. Should periodic coil cleaning be necessary, use standard coil cleaning procedures which are compatible with either the heat exchanger material or copper water lines. Generally, the more water flowing through the unit the less chance for scaling therefore 1.5 gpm per ton is recommended as a minimum flow.

Water Coil Maintenance

(All Other Water Loop Applications)

Generally water coil maintenance is not needed however, if the installation is located in a system with a known high dirt or debris content, it is best to establish with the owner a periodic maintenance schedule so the coil can be checked regularly. These dirty installations are a result of the deterioration of iron or galvanized piping or components in the system or open cooling towers requiring heavy chemical treatment and mineral buildup through water use. Should periodic coil cleaning be necessary, use standard coil cleaning procedures which are compatible with both the heat exchanger material and copper water lines. Generally, the more water flowing through the unit, the less chance for scaling, however flow rates over 3 gpm per ton can produce water (or debris) velocities that can erode the heat exchanger wall and ultimately produce leaks.

Compressor

Conduct annual amperage checks to ensure amp draw is no more than 10% greater than that indicated by serial plate data.

Cabinet

Do not allow water to stay in contact with the cabinet for long periods of time to prevent corrosion of the cabinet sheet metal. Generally vertical cabinets are set up from the floor a few inches for prevention. The cabinet can be cleaned using a mild detergent.

Refrigerant System

To maintain sealed circuit integrity, do not install service gauges unless unit operation appears abnormal. Reference the operating chart for pressure and temperatures. Verify that air and water flow rates are at proper levels before servicing the refrigerant circuit.

Revision History

Date	Page #	Description
10 June, 08	All	Reformatted Document Size
01 Oct, 06	All	First Published

97B0008N03
97B0008N03

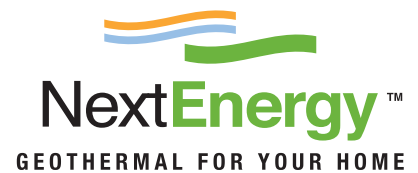

35 Earl Martin Dr.
Elmira, ON N3B 3L4
phone: 1-800-367-9810
fax: 1-877-684-3112
www.nextenergy.ca

ClimateMaster works continually to improve its products. As a result, the design and specifications of each product at the time of order may be changed without notice and may not be as described herein. Please contact ClimateMaster's Customer Service Department at 1-405-745-6000 for specific information on the current design and specifications. Statements and other information contained herein are not express warranties and do not form the basis of any bargain between the parties, but are merely ClimateMaster's opinion or commendation of its products. For the latest version of this document go to climatemaster.com.