



NextEnergy™

GEOTHERMAL FOR YOUR HOME

Split Products



Tranquility 27™ Split (TTS) Series

Tranquility 27™ Split (TTP) Series

Indoor and Outdoor Split
Geothermal Heat Pumps

Installation, Operation &
Maintenance Instructions

97B0047N02

Revision: 16 Dec., 2009B

Table of Contents

Model Nomenclature	3
Safety	4
Storage	5
Pre-Installation	5
Equipment Selection	6
Air Coil Match-ups	6-7
Air Handler Selection	8
Installation	9
Water Connections	10
Ground-Loop Heat Pump Applications	12-14
Ground-Water Heat Pump Applications - “Indoor” Compressor Section Only	15
Water Quality Standards	17
Lineset Information	18
Refrigeration Installation	19-25
Indoor Compressor Section	26
Hot Water Generator	27-28
Hot Water Generator Module Refrigeration Installation	29-29
Outdoor Compressor Section Only	29-30
Electrical - Line Voltage	31
Electrical - Power Wiring	32
Electrical - HWG Wiring	32
Electrical - Low Voltage Wiring	33-35
Thermostat Wiring	35
CXM Controls	36-38
Unit Starting and Operating Conditions	39-40
Unit Start-Up Procedure	41
Unit Operating Conditions	42-43
Preventive Maintenance	44
Troubleshooting	45
CXM Process Flow Chart	46
Functional Troubleshooting	47-48
Performance Troubleshooting	48
Troubleshooting Form	49
Revision History	50

Model Nomenclature: for Indoor Split Series

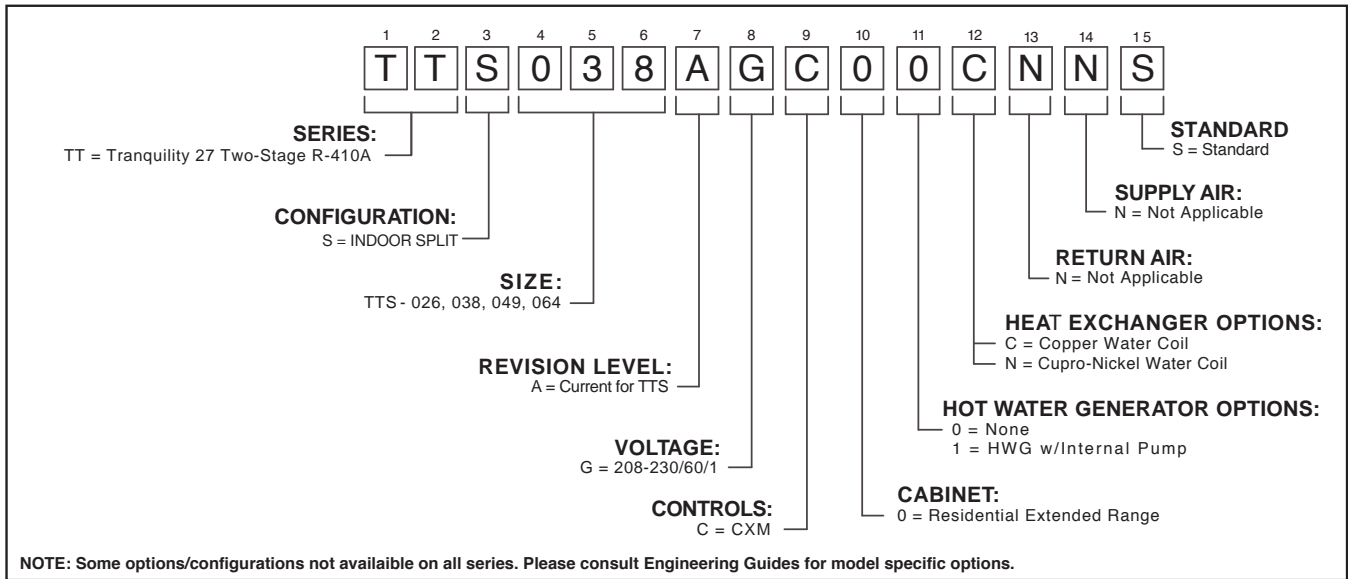

NOTE: Above model nomenclature is a general reference. Consult individual specification catalogs for detailed information.

Rev.: 06/09/09P

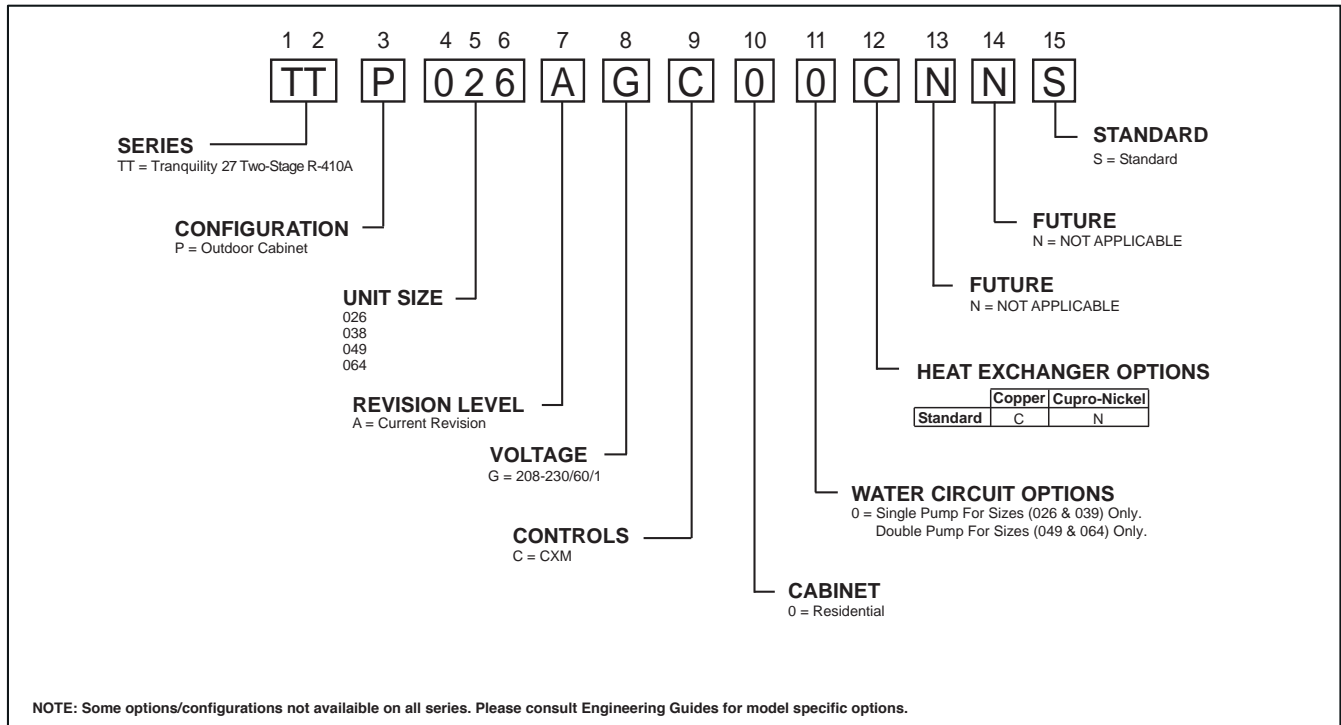

NOTE: Above model nomenclature is a general reference. Consult individual specification catalogs for detailed information.

Rev.: 08/12/09B

Safety

Safety

Warnings, cautions and notices appear throughout this manual. Read these items carefully before attempting any installation, service or troubleshooting of the equipment.

DANGER: Indicates an immediate hazardous situation, which if not avoided will result in death or serious injury. DANGER labels on unit access panels must be observed.

WARNING: Indicates a potentially hazardous situation, which if not avoided could result in death or serious injury.

CAUTION: Indicates a potentially hazardous situation or an unsafe practice, which if not avoided could result in minor or moderate injury or product or property damage.

NOTICE: Notification of installation, operation or maintenance information, which is important, but which is not hazard-related.

⚠ WARNING! ⚠

WARNING! The EarthPure® Application and Service Manual should be read and understood before attempting to service refrigerant circuits with HFC-410A.

⚠ WARNING! ⚠

WARNING! To avoid the release of refrigerant into the atmosphere, the refrigerant circuit of this unit must be serviced only by technicians who meet local, state, and federal proficiency requirements.

⚠ WARNING! ⚠

WARNING! All refrigerant discharged from this unit must be recovered WITHOUT EXCEPTION. Technicians must follow industry accepted guidelines and all local, state, and federal statutes for the recovery and disposal of refrigerants. If a compressor is removed from this unit, refrigerant circuit oil will remain in the compressor. To avoid leakage of compressor oil, refrigerant lines of the compressor must be sealed after it is removed.

⚠ CAUTION! ⚠

CAUTION! To avoid equipment damage, DO NOT use these units as a source of heating or cooling during the construction process. The mechanical components and filters will quickly become clogged with construction dirt and debris, which may cause system damage.

General Information

Inspection

Upon receipt of the equipment, carefully check the shipment against the bill of lading. Make sure all units have been received. Inspect the packaging of each unit, and inspect each unit for damage. Insure that the carrier makes proper notation of any shortages or damage on all copies of the freight bill and completes a common carrier inspection report. Concealed damage not discovered during unloading must be reported to the carrier within 15 days of receipt of shipment. If not filed within 15 days, the freight company can deny the claim without recourse. Note: It is the responsibility of the purchaser to file all necessary claims with the carrier. Notify your equipment supplier of all damage within fifteen (15) days of shipment.

Storage

Equipment should be stored in its original packaging in a clean, dry area. Store units in an upright position at all times. Stack units a maximum of 3 units high.

Unit Protection

Cover units on the job site with either the original packaging or an equivalent protective covering. Cap the open ends of pipes stored on the job site. In areas where painting, plastering, and/or spraying has not been completed, all due precautions must be taken to avoid physical damage to the units and contamination by foreign material. Physical damage and contamination may prevent proper start-up and may result in costly equipment clean-up.

Examine all pipes, fittings, and valves before installing any of the system components. Remove any dirt or debris found in or on these components.

Pre-Installation

Installation, Operation, and Maintenance instructions are provided with each unit. Horizontal equipment is designed for installation above false ceiling or in a ceiling plenum. Other unit configurations are typically installed in a mechanical room. The installation site chosen should include adequate service clearance around the unit. Before unit start-up, read all manuals and become familiar with the unit and its operation. Thoroughly check the system before operation.

Prepare units for installation as follows:

1. Compare the electrical data on the unit nameplate with ordering and shipping information to verify that the correct unit has been shipped.
2. Keep the cabinet covered with the original packaging until installation is complete and all plastering, painting, etc. is finished.
3. Verify refrigerant tubing is free of kinks or dents and that it does not touch other unit components.
4. Inspect all electrical connections. Connections must be clean and tight at the terminals.

5. Loosen compressor bolts on units equipped with compressor spring vibration isolation until the compressor rides freely on the springs. Remove shipping restraints.
6. Locate and verify any hot water generator (HWG) or other accessory kit located in the compressor section.

⚠ CAUTION! ⚠

CAUTION! DO NOT store or install units in corrosive environments or in locations subject to temperature or humidity extremes (e.g., attics, garages, rooftops, etc.). Corrosive conditions and high temperature or humidity can significantly reduce performance, reliability, and service life. Always move and store units in an upright position. Tilting units on their sides may cause equipment damage.

NOTICE! Failure to remove shipping brackets from spring-mounted compressors will cause excessive noise, and could cause component failure due to added vibration.

⚠ CAUTION! ⚠

CAUTION! CUT HAZARD - Failure to follow this caution may result in personal injury. Sheet metal parts may have sharp edges or burrs. Use care and wear appropriate protective clothing, safety glasses and gloves when handling parts and servicing heat pumps.

Equipment Selection

The installation of geothermal heat pump units and all associated components, parts, and accessories which make up the installation shall be in accordance with the regulations of ALL authorities having jurisdiction and MUST conform to all applicable codes. It is the responsibility of the installing contractor to determine and comply with ALL applicable codes and regulations.

General

Proper indoor coil selection is critical to system efficiency. Using an older-model coil can affect efficiency and may not provide the customer with rated or advertised EER and COP. Coil design and technology have dramatically improved operating efficiency and capacity in the past 20 years. Homeowners using an older coil are not reaping these cost savings and comfort benefits. NEVER MATCH AN R-22 INDOOR COIL WITH AN R-410A COMPRESSOR SECTION.

Newer indoor coils have a larger surface area, enhanced fin design, and grooved tubing. These features provide a larger area for heat transfer, improving efficiency and expanding capacity. Typical older coils may only have one-third to one-half the face area of these redesigned coils.

Indoor Coil Selection - Tranquility 27 (TTS & TTP)

ClimateMaster split system heat pumps are rated in the AHRI directory with a specific indoor coil match. Tranquility 27 models are rated with Carrier/Bryant FV4 or FE4 series variable speed air handlers as shown in Table 1a. Matches with Rheem/Ruud air handlers are shown in Table 1b. Other brands of air handlers may attain the same AHRI ratings providing that the specifications meet or exceed those listed in Table 1a or 1b AND Table 1c. An ECM motor and TXV is required. Cap tubes and fixed orifices are not acceptable. PSC fans may be used if matched to Table 1c, but will not meet AHRI ratings. If using PSC fan, compressor section must be operated as a single stage unit (i.e. wired for either 1st stage or 2nd stage). Without the ability to vary the airflow, supply air temperatures may not be acceptable if the compressor is allowed to change stages when used with a PSC fan motor.

Table 1a: Tranquility27™ Carrier/Bryant Air Handler Matches for AHRI Ratings

Compressor Section	026	038	049	064
Air Handler Model FV4	003	005	006	006
Refrigerant	R-410A			
Metering Device	TXV (required)			
Air Coil Type	Slope	A	A	A
Rows - Fins/in.	3 - 14.5	3 - 14.5	3 - 14.5	3 - 14.5
Face Area (sq. ft.)	3.46	5.93	7.42	7.42
Cabinet Configuration	Upflow/Downflow/Horizontal (Multipoise)			
ECM Settings for AHRI Ratings (FV4 Fan Coil)	AC/HP size: 036 System Type: Comfort AC/HP CFM Adjust: Nom	AC/HP size: 036 System Type: HP-Effic AC/HP CFM Adjust: High	AC/HP size: 048 System Type: Comfort AC/HP CFM Adjust: High	AC/HP size: 060 System Type: Comfort AC/HP CFM Adjust: High
Fan Motor Type - HP	ECM - 1/2	ECM - 1/2	ECM - 3/4	ECM - 3/4

Equipment Selection

Table 1b: Tranquility 27™ Rheem/Ruud Air Handler Matches for AHRI Ratings

Compressor Section	026	038	049	064
Air Handler Model	RHPL-HM2421	RHPL-HM3621	RHPL-HM24	RHPL-HM6024
Refrigerant	410A			
Metering Device	TXV (Non Bleed) required			
Air Coil Type Rows - Fins/in. Face Area (sq. ft.)	N Style 2 - 16 fpi 5.7	N Style 2 - 16 fpi 5.7	N Style 2 - 16 fpi 8.55	N Style 3 - 14 fpi 9.98
Cabinet Configuration	Upflow/Downflow/Horizontal (Multiposition)			
ECM Settings	Rheem Comfort Control System	Rheem Comfort Control System	Rheem Comfort Control System	Rheem Comfort Control System
Fan Motor Type - HP	ECM - 1/3 HP	ECM - 1/2 HP	ECM - 3/4 HP	ECM - 3/4 HP

Table 1c: Tranquility 27™ Air Handler Characteristics for Brands other than Above Models

Model*	Nominal Tons*	Evaporator Temp (°F)	CFM	Capacity (MBtuh)**
026 - Part Load	1.5	50	530	19.2 - 22.4
026 - Full Load	2.0	52	880	24.2 - 28.2
038 - Part Load	2.5	51	700	25.2 - 29.2
038 - Full Load	3.0	50	1200	34.5 - 40.1
049 - Part Load	3.5	47	1000	34.3 - 39.9
049 - Full Load	4.0	48	1650	46.3 - 53.8
064 - Full Load	5.0	48	1850	54.5 - 63.3

* Nominal tons are at AHRI/ISO 13256-1 GLHP conditions. Two-stage units may be operated in single-stage mode if desired, where smaller capacity is required. For example, a model 026 may be used as a 1-1/2 ton unit if "locked" into 1st stage operation only. If PSC fan is used, unit must be "locked" into either 1st or 2nd stage. An ECM fan is required for two-stage operation and for AHRI ratings. Size air handler for "Full Load" if operating in two-stage mode.

**When selecting an air handler based upon the above conditions, choose entering WB temperature of 67°F. Use evaporator temperature, CFM and capacity requirements as listed above. The air handler capacity must be at least at the minimum capacity shown in the table in order for the AHRI rating condition to be valid. See Figure 1 for an example selection.

Equipment Selection

Air Handler Selection Example

Figure 1 shows a typical performance table for a heat pump air handler. Suppose the evaporator temperature required is 50°F, the capacity required is 35,000 Btuh and the airflow required is 1,200 CFM. Each evaporator temperature listed in the table shows three wet bulb temperatures. As recommended in the table notes above, select the 67°F WB column. At 1,200 CFM, the model 003 capacity is 36 MBtuh, which is higher than the minimum capacity required of 35,000 Btuh. In this example, model 003 would be the appropriate match.

Figure 1: Selecting Air Handler

Unit Size	Evaporator Air CFM	Coil Refrigerant Temperature (°F)*																			
		35				40				45				50				55			
		Evaporator Air - Entering Wet-Bulb Temperature (°F)																			
	BF	72	67	62	72	67	62	72	67	62	72	67	62	72	67	62					
003	800	59	48	38	53	42	32	46	35	24	39	27	20	30	18	16					
	0.20	28	29	31	25	27	28	22	23	24	19	20	20	16	16	16					
	1000	68	56	45	61	49	37	54	41	29	45	32	25	35	22	20					
	0.22	32	34	37	29	31	33	26	28	28	23	24	25	19	20	20					
	1200	75	62	49	68	54	42	60	45	34	50	36	29	40	25	23					
	0.25	35	39	42	32	36	28	29	32	33	26	28	29	22	23	23					
005	1400	80	67	54	73	59	46	64	49	38	54	39	32	43	28	27					
	0.27	28	43	47	35	39	43	32	36	37	28	32	32	24	26	27					
	750	61	49	39	55	43	33	48	37	27	41	29	20	33	21	17					
	0.04	27	27	28	24	25	25	21	22	22	18	18	18	15	15	15					
	950	74	60	48	67	53	40	59	45	33	50	35	25	39	24	21					
	0.06	32	34	35	29	30	31	25	26	27	22	23	23	18	18	19					
006	1150	89	72	57	79	63	48	69	52	38	58	41	31	44	29	25					
	0.07	37	39	41	33	35	36	29	31	32	25	25	27	20	22	22					
	1500	103	84	66	92	73	56	81	61	46	67	48	39	52	34	31					
	0.10	43	46	49	38	41	44	34	37	39	29	32	33	25	27	27					
	1700	110	89	71	99	78	60	86	65	49	72	51	42	56	37	35					
	0.11	45	50	53	41	45	48	36	39	42	31	34	36	27	29	30					
006	1050	77	62	50	69	55	43	61	47	32	52	38	27	41	27	22					
	0.01	34	36	37	31	32	33	27	28	29	23	25	24	20	20	20					
	1300	100	82	65	90	71	55	79	60	45	66	47	37	49	32	27					
	0.02	42	45	47	37	40	42	33	35	37	29	31	32	23	25	24					
	1750	117	96	77	106	84	65	93	71	53	78	56	46	60	40	34					
	0.04	48	53	57	44	48	52	39	43	46	34	38	39	29	31	31					
006	2050	126	103	83	114	91	71	99	76	59	84	60	50	65	44	39					
	0.05	52	58	63	48	53	57	43	47	51	37	42	43	33	35	35					
	2300	132	108	87	119	95	75	105	80	63	88	63	54	70	47	42					
	0.06	55	62	68	50	57	61	45	51	54	40	45	46	35	39	38					

= Gross cooling capacity (MBtuh)
 = Sensible heat capacity (MBtuh)
 BF = Bypass Factor

Installation

NOTICE! Failure to remove shipping brackets from spring-mounted compressors will cause excessive noise, and could cause component failure due to added vibration.

The installation of water source heat pump units and all associated components, parts and accessories which make up the installation shall be in accordance with the regulations of ALL authorities having jurisdiction and MUST conform to all applicable codes. It is the responsibility of the installing contractor to determine and comply with ALL applicable codes and regulations.

Removing Existing Condensing Unit (Where Applicable)

1. Pump down condensing unit. Close the liquid line service valve of existing condensing unit and start compressor to pump refrigerant back into compressor section. Then, close suction service valve while compressor is still running to trap refrigerant in outdoor section. Immediately kill power to the condensing unit.
2. Disconnect power and low voltage and remove old condensing unit. Cut or unbraid line set from unit. Remove condensing unit.
3. If condensing unit is not operational or will not pump down, refrigerant should be recovered using appropriate equipment.
4. Replace line set, especially if upgrading system from R-22 to R-410A refrigerant. If line set cannot be replaced, it must be thoroughly flushed before installing new compressor section. R-410A compressors use POE oil instead of mineral oil (R-22 systems). Mineral oil is not compatible with POE oil, and could cause system damage if not completely flushed from the line set.

“Indoor” Compressor Section Location

Both “indoor” and “outdoor” versions of the geothermal split system compressor section are available. “Indoor” version is not designed for outdoor installation. Locate the unit in an INDOOR area that allows enough space for service personnel to perform typical maintenance or repairs without removing unit. Units are typically installed in a mechanical room or closet. Never install units in areas subject to freezing or where humidity levels could cause cabinet condensation (such as unconditioned spaces subject to 100% outside air). Consideration should be given to access for easy removal of service access panels. Provide sufficient room to make water, electrical, and line set connections.

Any access panel screws that would be difficult to remove after the unit is installed should be removed prior to setting the unit. Refer to Figure 2 for an illustration of a typical installation. Refer to “Physical Dimensions” section for dimensional data. Conform to the following guidelines when selecting unit location:

1. Install the unit on a piece of rubber, neoprene or other mounting pad material for sound isolation. The pad should be at least 3/8” [10mm] to 1/2” [13mm] in thickness. Extend the pad beyond all four edges of the unit.

2. Provide adequate clearance for maintenance and service. Do not block access panels with piping, conduit or other materials.
3. Provide access for servicing the compressor and coils without removing the unit.
4. Provide an unobstructed path to the unit within the closet or mechanical room. Space should be sufficient to allow removal of the unit, if necessary.
5. Provide access to water valves and fittings and screwdriver access to the unit side panels and all electrical connections.

“Outdoor” Compressor Section Location

Locate the unit in an outdoor area that allows easy loop and lineset access and also has enough space for service personnel to perform typical maintenance or repairs. The “outdoor” compressor section is usually installed on a condenser pad directly outside the lineset access into the building. The loop access end should be located away from the building. Conform to the following guidelines when selecting unit location:

1. Provide adequate access for loop trench excavation.
2. Locate unit directly outside lineset penetration if possible. Utilize existing condenser pad where possible.
3. Provide access for servicing and maintenance.

“Outdoor” compressor section may be mounted on a vibration isolation pad with loop access hole as shown in Figure 3. When mounting on an existing concrete condenser pad, 3” [76 mm] holes should be bored through the pad to accommodate the pipe (1-1/4” - 32mm) and insulation (1/2” [13mm] wall thickness). Figure 3 illustrates location and dimensions of the holes required.

Air Handler Installation

This manual specifically addresses the compressor section of the system. Air handler location and installation should be according to the instructions provided with the air handling unit.

Installation

Figure 2: TTS Installation

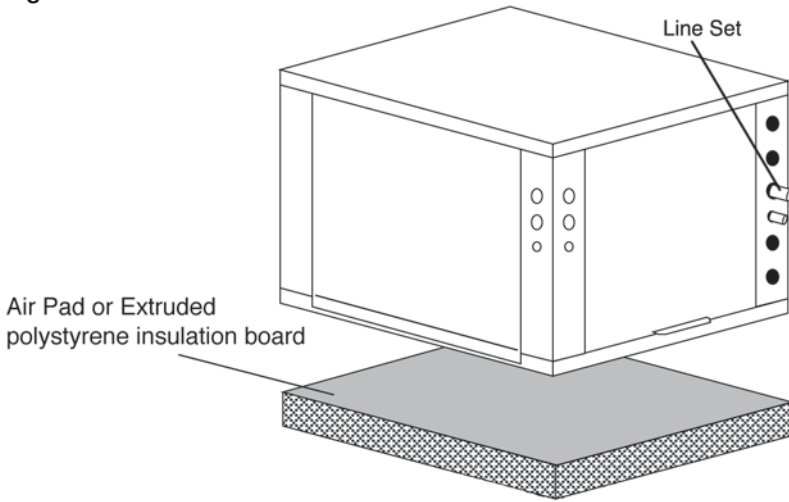
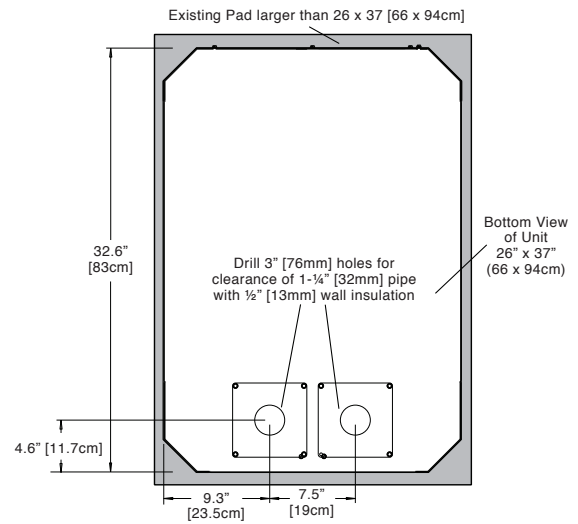
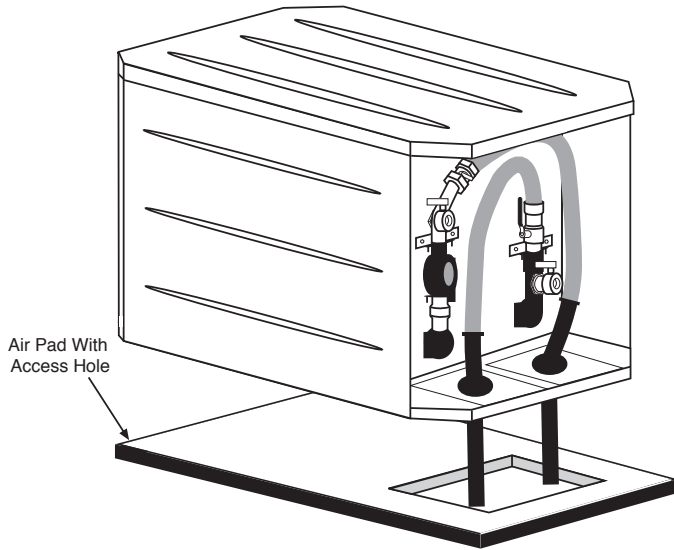

Figure 3: TTP Installation



External Flow Controller Mounting

The Flow Controller can be mounted beside the indoor unit as shown in Figure 7. Review the Flow Controller installation manual for more details.

Water Connections-Residential (TTS Series) Models

Residential models utilize swivel piping fittings for water connections that are rated for 450 psi (3101 kPa) operating pressure. The connections have a rubber gasket seal similar to a garden hose gasket, which when mated to the flush end of most 1" threaded male pipe fittings provides a leak-free seal without the need for thread sealing tape or joint compound. Insure that the rubber seal is in the swivel connector prior to attempting any connection (rubber seals are shipped attached to the swivel connector). **DO NOT OVERTIGHTEN** or leaks may occur.

The female locking ring is threaded onto the pipe threads which holds the male pipe end against the rubber gasket, and seals the joint. **HAND TIGHTEN ONLY! DO NOT OVERTIGHTEN!**

Figure 4: Water Connections (TTS Series)

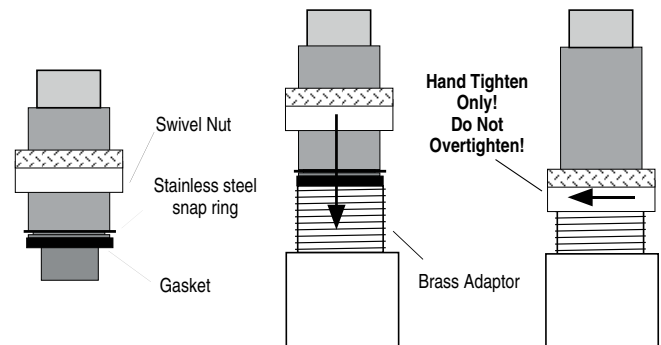

Installation

Internal Flow Controller Connections (TTP Series)

The TTP series outdoor compressor section includes a factory built-in circulator, as shown in figure 3. This circulator includes a built-in check valve, which is needed when connecting multiple units to a common loop.

The circulator in the TTP unit is three speed (shipped on high speed). Lower circulator speeds may be chosen where appropriate to lower pumping power and match the flow rate to the unit's requirements. The pump curves for this circulator are shown in Figure 6.

TTP026 and 038 units come standard with one circulator. TTP049 and 064 units come standard with two circulators, piped in series for greater flow and head capabilities.

TTP026 and 038 units are shipped with 3/4" stainless steel braided hoses connected to unit piping. These hoses terminate in swivel connections.

TTP049 and 064 units are shipped with 1" stainless steel braided hoses connected to unit piping. These hoses terminate in swivel connections.

Figure 5: Hose Connections (TTP Series)

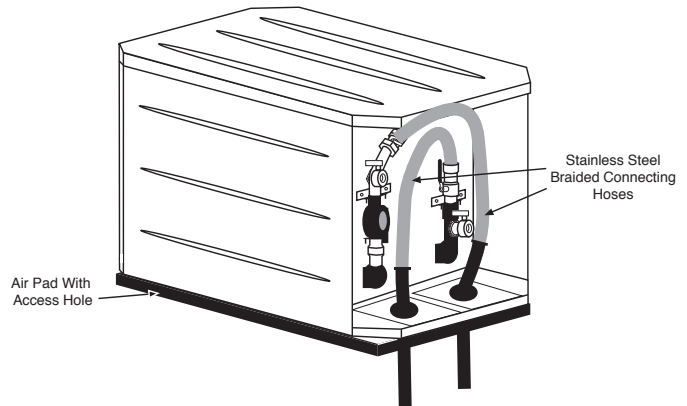

⚠ CAUTION! ⚠

CAUTION! To avoid equipment damage, DO NOT allow system water pressure to exceed 100 psi. when using the TTP Outdoor Compressor Section. The expansion tank in the TTP has a maximum working water pressure of 100 psi. Any pressure in excess of 100 psi may damage the expansion tank.

Figure 6: Pump Curves for TTP internal pump(s) - Single Pump

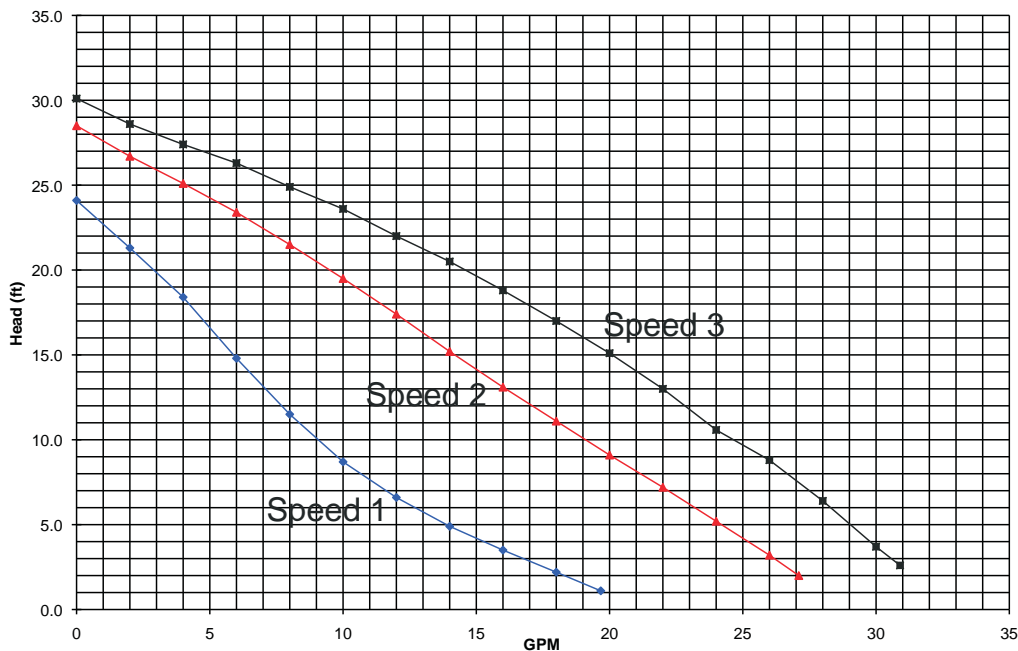

Double Pump Table on following page

Installation

Figure 6: Pump Curves for TTP internal pump(s) - Double Pump

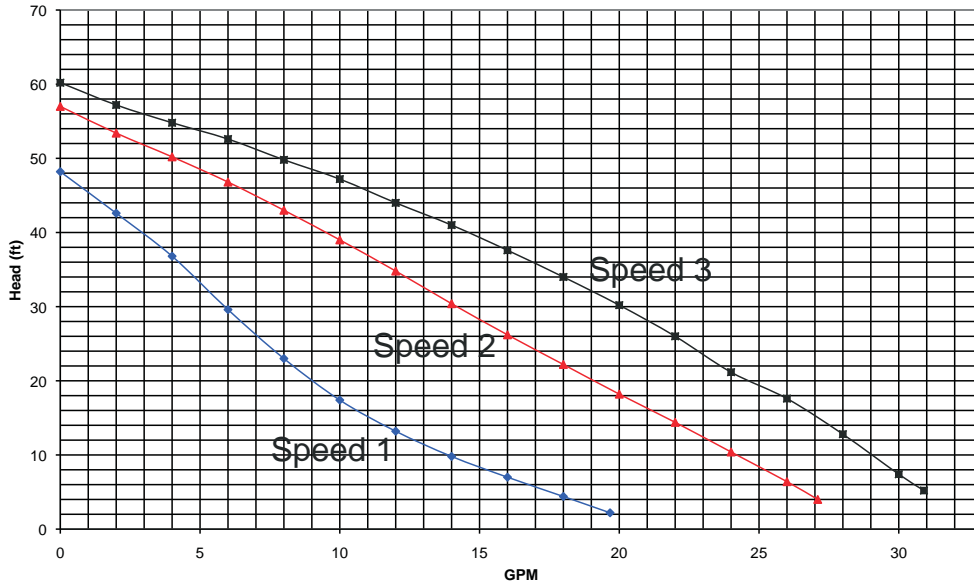

Ground-Loop Heat Pump Applications

⚠ CAUTION! ⚠

CAUTION! The following instructions represent industry accepted installation practices for closed loop earth coupled heat pump systems. Instructions are provided to assist the contractor in installing trouble free ground loops. These instructions are recommendations only. State/provincial and local codes **MUST** be followed and installation **MUST** conform to **ALL** applicable codes. It is the responsibility of the installing contractor to determine and comply with **ALL** applicable codes and regulations.

Pre-Installation

Prior to installation, locate and mark all existing underground utilities, piping, etc. Install loops for new construction before sidewalks, patios, driveways, and other construction has begun. During construction, accurately mark all ground loop piping on the plot plan as an aid in avoiding potential future damage to the installation.

Piping Installation

The typical closed loop ground source system is shown in Figure 7. All earth loop piping materials should be limited to polyethylene fusion only for in-ground sections of the loop. Galvanized or steel fittings should not be used at any time due to their tendency to corrode. All plastic to metal threaded fittings should be avoided due to their potential to leak in earth coupled applications. A flanged fitting should be substituted. P/T plugs should be used so that flow can be measured using the pressure drop of the unit heat exchanger.

Ground-Loop Heat Pump Applications

Earth loop temperatures can range between 25 and 110°F [-4 to 43°C]. Flow rates between 2.25 and 3 gpm per ton [2.41 to 3.23 l/m per kW] of cooling capacity is recommended in these applications.

Test individual horizontal loop circuits before backfilling. Test vertical U-bends and pond loop assemblies prior to installation. Pressures of at least 100 psi [689 kPa] should be used when testing. Do not exceed the pipe pressure rating. Test entire system when all loops are assembled.

Flushing the Earth Loop

Once piping is completed between the unit, Flow Controller and the ground loop (Figure 7), the loop is ready for final purging and charging. A flush cart with at least a 1.5 hp [1.1 kW] pump is required to achieve enough fluid velocity in the loop piping system to purge air and dirt particles. An antifreeze solution is used in most areas to prevent freezing. All air and debris must be removed from the earth loop piping before operation. Flush the loop with a high volume of water at a minimum velocity of 2 fps (0.6 m/s) in all piping. The steps below must be followed for proper flushing.

1. Fill loop with water from a garden hose through the flush cart before using the flush cart pump to insure an even fill.
2. Once full, the flushing process can begin. Do not allow the water level in the flush cart tank to drop below the pump inlet line to avoid air being pumped back out to the earth loop.
3. Try to maintain a fluid level in the tank above the return tee so that air cannot be continuously mixed back into the fluid. Surges of 50 psi (345 kPa) can be used to help purge air pockets by simply shutting off the return valve going into the flush cart reservoir. This “dead heads” the pump to 50 psi (345 kPa). To purge, dead head the pump until maximum pumping pressure is reached. Open the return valve and a pressure surge will be sent through the loop to help purge air pockets from the piping system.
4. Notice the drop in fluid level in the flush cart tank when the return valve is shut off. If air is adequately purged from the system, the level will drop only 1-2 inches (2.5 - 5 cm) in a 10” (25 cm) diameter PVC flush tank (about a half gallon [2.3 liters]), since liquids are incompressible. If the level drops more than this, flushing should continue since air is still being compressed in the loop fluid. Perform the “dead head” procedure a number of times.

Note: This fluid level drop is your only indication of air in the loop.

Antifreeze may be added before, during or after the flushing procedure. However, depending upon which time is chosen, antifreeze could be wasted when emptying the flush cart tank. See antifreeze section for more details.

Loop static pressure will fluctuate with the seasons. Pressures will be higher in the winter months than during the cooling season. This fluctuation is normal and should be considered when charging the system initially. Run the unit in either heating or cooling for a number of minutes to condition the loop to a homogenous temperature. This is a good time for tool cleanup, piping insulation, etc. Then, perform final flush and pressurize the loop to a static pressure of 50-75 psi [345-517 kPa] (winter) or 35-40 psi [241-276 kPa] (summer). After pressurization, be sure to loosen the plug at the end of the Grundfos loop pump motor(s) to allow trapped air to be discharged and to insure the motor housing has been flooded. This is not required for Taco circulators. Insure that the Flow Controller provides adequate flow through the unit by checking pressure drop across the heat exchanger and compare to the pressure drop tables at the back of the manual.

⚠ CAUTION! ⚠

CAUTION! To avoid equipment damage, DO NOT allow system water pressure to exceed 100 psi. when using the TTP Outdoor Compressor Section. The expansion tank in the TTP has a maximum working water pressure of 100 psi. Any pressure in excess of 100 psi may damage the expansion tank.

Antifreeze

In areas where minimum entering loop temperatures drop below 40°F [5°C] or where piping will be routed through areas subject to freezing, antifreeze is required. Alcohols and glycols are commonly used as antifreeze; however your local sales manager should be consulted for the antifreeze best suited to your area. Freeze protection should be maintained to 15°F [9°C] below the lowest expected entering loop temperature. For example, if 30°F [-1°C] is the minimum expected entering loop temperature, the leaving loop temperature would be 25 to 22°F [-4 to -6°C] and freeze protection should be at 15°F [-10°C]. Calculation is as follows:

$$30^{\circ}\text{F} - 15^{\circ}\text{F} = 15^{\circ}\text{F} \quad [-1^{\circ}\text{C} - 9^{\circ}\text{C} = -10^{\circ}\text{C}].$$

All alcohols should be premixed and pumped from a reservoir outside of the building when possible or introduced under the water level to prevent fumes. Calculate the total volume of fluid in the piping system. Then use the percentage by volume shown in Table 3 for the amount of antifreeze needed. Antifreeze concentration should be checked from a well mixed sample using a hydrometer to measure specific gravity.

Low Water Temperature Cutout Setting - CXM Control

When antifreeze is selected, the FP1 jumper (JW3) should be clipped to select the low temperature (antifreeze 13°F [-10.6°C]) set point and avoid nuisance faults (see “Low Water Temperature Cutout Selection” in this manual). NOTE: Low water temperature operation requires extended range equipment.

Ground-Loop Heat Pump Applications

Table 2: Approximate Fluid Volume (U.S. gal. [L]) per 100' of Pipe

Fluid Volume (gal [liters] per 100' [30 meters] Pipe)		
Pipe	Size	Volume (gal) [liters]
Copper	1"	4.1 [15.3]
	1.25"	6.4 [23.8]
	2.5"	9.2 [34.3]
Rubber Hose	1"	3.9 [14.6]
Polyethylene	3/4" IPS SDR11	2.8 [10.4]
	1" IPS SDR11	4.5 [16.7]
	1.25" IPS SDR11	8.0 [29.8]
	1.5" IPS SDR11	10.9 [40.7]
	2" IPS SDR11	18.0 [67.0]
	1.25" IPS SCH40	8.3 [30.9]
	1.5" IPS SCH40	10.9 [40.7]
	2" IPS SCH40	17.0 [63.4]
Unit Heat Exchanger	Typical	1.0 [3.8]
Flush Cart Tank	10" Dia x 3ft tall [254mm x 91.4cm tall]	10 [37.9]

Figure 7: Loop Connection (Indoor Compressor Section)

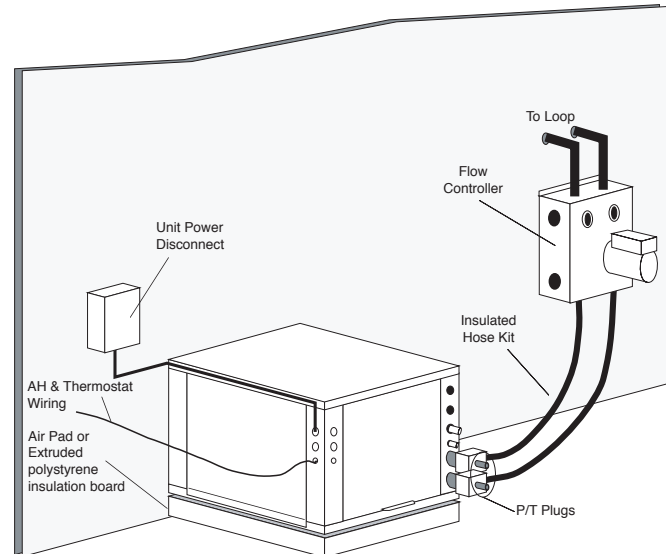

Table 3: Antifreeze Percentages by Volume

Type	Minimum Temperature for Low Temperature Protection			
	10°F [-12.2°C]	15°F [-9.4°C]	20°F [-6.7°C]	25°F [-3.9°C]
Methanol	25%	21%	16%	10%
100% USP food grade Propylene Glycol	38%	25%	22%	15%
Ethanol*	29%	25%	20%	14%

* Must not be denatured with any petroleum based product

Ground-Water Heat Pump Applications - “Indoor” Compressor Section Only

Open Loop - Ground Water Systems

Typical open loop piping is shown in Figure 8. Shut off valves should be included for ease of servicing. Boiler drains or other valves should be “tee’d” into the lines to allow acid flushing of the heat exchanger. Shut off valves should be positioned to allow flow through the coax via the boiler drains without allowing flow into the piping system. P/T plugs should be used so that pressure drop and temperature can be measured. Piping materials should be limited to copper or PVC SCH80. Note: Due to the pressure and temperature extremes, PVC SCH40 is not recommended.

Water quantity should be plentiful and of good quality. Consult Table 4 for water quality guidelines. The unit can be ordered with either a copper or cupro-nickel water heat exchanger. Consult Table 4 for recommendations. Copper is recommended for closed loop systems and open loop ground water systems that are not high in mineral content or corrosiveness. In conditions anticipating heavy scale formation or in brackish water, a cupro-nickel heat exchanger is recommended. In ground water situations where scaling could be heavy or where biological growth such as iron bacteria will be present, an open loop system is not recommended. Heat exchanger coils may over time lose heat exchange capabilities due to build up of mineral deposits. Heat exchangers must only be serviced by a qualified technician, as acid and special pumping equipment is required. Desuperheater coils can likewise become scaled and possibly plugged. In areas with extremely hard water, the owner should be informed that the heat exchanger may require occasional acid flushing. In some cases, the desuperheater option should not be recommended due to hard water conditions and additional maintenance required.

Water Quality Standards

Table 4 should be consulted for water quality requirements. Scaling potential should be assessed using the pH/Calcium hardness method. If the pH <7.5 and the Calcium hardness is less than 100 ppm, scaling potential is low. If this method yields numbers out of range of those listed, the Ryznar Stability and Langelier Saturation indices should be calculated. Use the appropriate scaling surface temperature for the application, 150°F [66°C] for direct use (well water/open loop) and DHW (desuperheater); 90°F [32°F] for indirect use. A monitoring plan should be implemented in these probable scaling situations. Other water quality issues such as iron fouling, corrosion prevention and erosion and clogging should be referenced in Table 4.

Expansion Tank and Pump

Use a closed, bladder-type expansion tank to minimize mineral formation due to air exposure. The expansion tank should be sized to provide at least one minute continuous run time of the pump using its drawdown capacity rating to prevent pump short cycling. Discharge water from the unit is not contaminated in any manner and can be disposed of in various ways, depending on local building codes (e.g. recharge well, storm sewer, drain field, adjacent stream

or pond, etc.). Most local codes forbid the use of sanitary sewer for disposal. Consult your local building and zoning department to assure compliance in your area.

The pump should be sized to handle the home's domestic water load (typically 5-9 gpm [23-41 l/m]) plus the flow rate required for the heat pump. Pump sizing and expansion tank must be chosen as complimentary items. For example, an expansion tank that is too small can causing premature pump failure due to short cycling. Variable speed pumping applications should be considered for the inherent energy savings and smaller expansion tank requirements.

Water Control Valve

Note the placement of the water control valve in figure 8. Always maintain water pressure in the heat exchanger by placing the water control valve(s) on the discharge line to prevent mineral precipitation during the off-cycle. Pilot operated slow closing valves are recommended to reduce water hammer. If water hammer persists, a mini-expansion tank can be mounted on the piping to help absorb the excess hammer shock. Insure that the total ‘VA’ draw of the valve can be supplied by the unit transformer. For instance, a slow closing valve can draw up to 35VA. This can overload smaller 40 or 50 VA transformers depending on the other controls in the circuit. A typical pilot operated solenoid valve draws approximately 15VA (see Figure 24). Note the special wiring diagrams for slow closing valves (Figures 25 & 26).

Flow Regulation

Flow regulation can be accomplished by two methods. One method of flow regulation involves simply adjusting the ball valve or water control valve on the discharge line. Measure the pressure drop through the unit heat exchanger, and determine flow rate from Table 14. Since the pressure is constantly varying, two pressure gauges may be needed. Adjust the valve until the desired flow of 1.5 to 2 gpm per ton [2.0 to 2.6 l/m per kW] is achieved. A second method of flow control requires a flow control device mounted on the outlet of the water control valve. The device is typically a brass fitting with an orifice of rubber or plastic material that is designed to allow a specified flow rate. On occasion, flow control devices may produce velocity noise that can be reduced by applying some back pressure from the ball valve located on the discharge line. Slightly closing the valve will spread the pressure drop over both devices, lessening the velocity noise. **NOTE: When EWT is below 50°F [10°C], a minimum of 2 gpm per ton (2.6 l/m per kW) is required.**

⚠ CAUTION! ⚠

CAUTION! To avoid equipment damage, DO NOT allow system water pressure to exceed 100 psi. when using the TTP Outdoor Compressor Section. The expansion tank in the TTP has a maximum working water pressure of 100 psi. Any pressure in excess of 100 psi may damage the expansion tank.

Ground-Water Heat Pump Applications

Water Coil Low Temperature Limit Setting

For all open loop systems the 30°F [-1.1°C] FP1 setting (factory setting-water) should be used to avoid freeze damage to the unit. See “Low Water Temperature Cutout Selection” in this manual for details on the low limit setting.

⚠ CAUTION! ⚠

CAUTION! Many units are installed with a factory or field supplied manual or electric shut-off valve. **DAMAGE WILL OCCUR** if shut-off valve is **closed** during unit operation. A high pressure switch must be installed on the heat pump side of any field provided shut-off valves and connected to the heat pump controls in series with the built-in refrigerant circuit high pressure switch to disable compressor operation if water pressure exceeds pressure switch setting. The field installed high pressure switch shall have a cut-out pressure of 300 psig and a cut-in pressure of 250 psig. This pressure switch can be ordered from ClimateMaster with a 1/4” internal flare connection as part number 39B0005N02.

⚠ CAUTION! ⚠

CAUTION! Refrigerant pressure activated water regulating valves should never be used with ClimateMaster equipment.

Figure 8: Water Well Connections

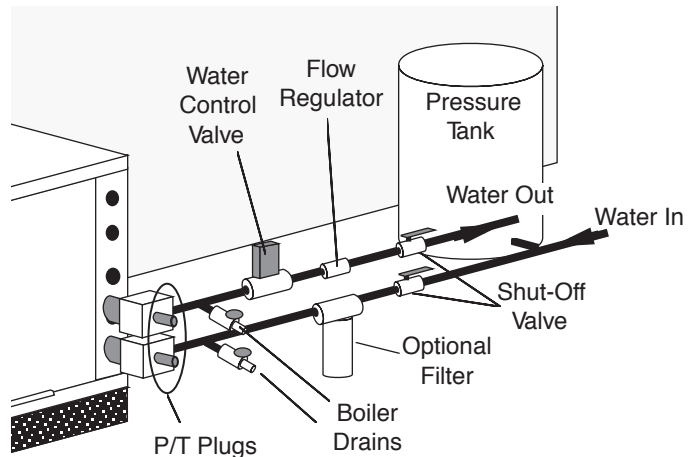

Water Quality Standards

Table 4: Water Quality Standards

Water Quality Parameter	HX Material	Closed Recirculating	Open Loop and Recirculating Well		
Scaling Potential - Primary Measurement					
Above the given limits, scaling is likely to occur. Scaling indexes should be calculated using the limits below					
pH/Calcium Hardness Method	All	-	pH < 7.5 and Ca Hardness <100ppm		
Index Limits for Probable Scaling Situations - (Operation outside these limits is not recommended)					
Scaling indexes should be calculated at 150°F [66°C] for direct use and HWG applications, and at 90°F [32°C] for indirect HX use. A monitoring plan should be implemented.					
Ryznar Stability Index	All	-	6.0 - 7.5 If >7.5 minimize steel pipe use.		
Langelier Saturation Index	All	-	-0.5 to +0.5 If <-0.5 minimize steel pipe use. Based upon 150°F [66°C] HWG and Direct well, 85°F [29°C] Indirect Well HX		
Iron Fouling					
Iron Fe ²⁺ (Ferrous) (Bacterial Iron potential)	All	-	<0.2 ppm (Ferrous) If Fe ²⁺ (ferrous)>0.2 ppm with pH 6 - 8, O ₂ <5 ppm check for iron bacteria		
Iron Fouling	All	-	<0.5 ppm of Oxygen Above this level deposition will occur.		
Corrosion Prevention					
pH	All	6 - 8.5 Monitor/treat as needed	6 - 8.5 Minimize steel pipe below 7 and no open tanks with pH <8		
Hydrogen Sulfide (H ₂ S)	All	-	<0.5 ppm At H ₂ S>0.2 ppm, avoid use of copper and copper nickel piping or HX's. Rotten egg smell appears at 0.5 ppm level. Copper alloy (bronze or brass) cast components are OK to <0.5 ppm.		
Ammonia ion as hydroxide, chloride, nitrate and sulfate compounds	All	-	<0.5 ppm		
Maximum Chloride Levels	Copper CuproNickel 304 SS 316 SS Titanium	- - - - -	Maximum Allowable at maximum water temperature.		
			50°F (10°C)	75°F (24°C)	100°F (38°C)
			<20ppm	NR	NR
			<150 ppm	NR	NR
			<400 ppm	<250 ppm	<150 ppm
<1000 ppm	<550 ppm	< 375 ppm			
>1000 ppm	>550 ppm	>375 ppm			
Erosion and Clogging					
Particulate Size and Erosion	All	<10 ppm of particles and a maximum velocity of 6 fps [1.8 m/s] Filtered for maximum 800 micron [800mm, 20 mesh] size.	<10 ppm (<1 ppm "sandfree" for reinjection) of particles and a maximum velocity of 6 fps [1.8 m/s]. Filtered for maximum 800 micron [800mm, 20 mesh] size. Any particulate that is not removed can potentially clog components.		

Notes:

Rev.: 01/21/09B

- Closed Recirculating system is identified by a closed pressurized piping system.
- Recirculating open wells should observe the open recirculating design considerations.
- NR - Application not recommended.
- "-" No design Maximum.

Refrigeration Installation

⚠ CAUTION! ⚠

CAUTION! R-410A systems operate at higher pressures than R-22 systems. Be certain that service equipment (gauges, tools, etc.) is rated for R-410A. Some R-22 service equipment may not be acceptable.

⚠ CAUTION! ⚠

CAUTION! Installation of a factory supplied liquid line bi-directional filter drier is required. Never install a suction line filter in the liquid line.

Line Set Installation

Figures 11a and 11b illustrate typical installations of a compressor section matched to either an air handler (fan coil) or add-on furnace coil. Table 5 shows typical line-set diameters at various lengths. Lineset lengths should be kept to a minimum and should always be installed with care to avoid kinking. Line sets over 60 feet [18 meters] long are not recommended due to potential oil transport problems and excessive pressure drop. If the line set is kinked or distorted, and it cannot be formed back into its original shape, the damaged portion of the line should be replaced. A restricted line set will effect the performance of the system.

Split units are shipped with a filter drier (loose) inside the cabinet that must be installed in the liquid line at the line set. **All brazing should be performed using nitrogen circulating at 2-3 psi [13.8-20.7 kPa] to prevent oxidation inside the tubing. All linesets should be insulated with a minimum of 1/2" [13mm] thick closed cell insulation. All insulation tubing should be sealed using a UV resistant paint or covering to prevent deterioration from sunlight.**

When passing refrigerant lines through a wall, seal opening with silicon-based caulk. Avoid direct contact with water pipes, duct work, floor joists, wall studs, floors or other structural components that could transmit compressor vibration. Do not suspend refrigerant tubing from joists with rigid straps. Do not attach line set to the wall. When necessary, use hanger straps with isolation sleeves to minimize transmission of line set vibration to the structure.

Installing the Lineset at the Compressor Section

Braze the line set to the service valve stubs as shown in Figure 9. On installations with long line sets, copper adapters may be needed to connect the larger diameter tube to the stubs. Nitrogen should be circulated through the system at 2-3 psi [13.8-20.7 kPa] to prevent oxidation contamination. Use a low silver phos-copper braze alloy on all brazed connections. **Compressor section is shipped with a factory charge. Therefore, service valves should not be opened until the line set has been leak tested, purged and evacuated.** See "Charging the System."

Installing the Indoor Coil and Lineset

Figure 10 shows the installation of the lineset and TXV to a typical indoor coil. An indoor coil or air handler (fan coil) with a TXV is required. Coils with cap tubes may not be used. If coil includes removable fixed orifice, the orifice must be removed and a TXV must be installed as shown in Figure 10. Fasten the copper line set to the coil. Nitrogen should be circulated through the system at 2-3 psi [13.8-20.7 kPa] to prevent oxidation inside the refrigerant tubing. Use a low silver phos-copper braze alloy on all brazed connections.

Table 5: Lineset Diameters and Charge Information

Model	Factory† Charge (oz) [kg]	Basic* Charge (oz) [kg]	20 Feet [6 meters]		40 Feet [12 meters]		60 Feet [18 meters]	
			Liquid	Suction	Liquid	Suction	Liquid	Suction
TTS/TTP Series								
026	90 [2.55]	75 [2.13]	3/8"	3/4"	3/8"	3/4"	3/8"	7/8"
038	104 [2.95]	89 [2.52]	3/8"	7/8"	3/8"	7/8"	3/8"	7/8"
049	126 [3.57]	111 [3.15]	3/8"	7/8"	3/8"	7/8"	1/2"	1-1/8"
064	168 [4.76]	138 [3.91]	1/2"	1-1/8"	1/2"	1-1/8"	1/2"	1-1/8"

• Basic charge includes only the amount required for the condensing unit and the evaporating coil. An additional amount should be added allowing 0.6oz per ft. for 3/8" [0.6g per cm] and 1.2oz per ft. for 1/2" [1.1g per cm] of lineset used.
 †Factory charge is preset for 25' [7.6 meters] lineset.

Refrigeration Installation

Figure 9: Braze Instructions

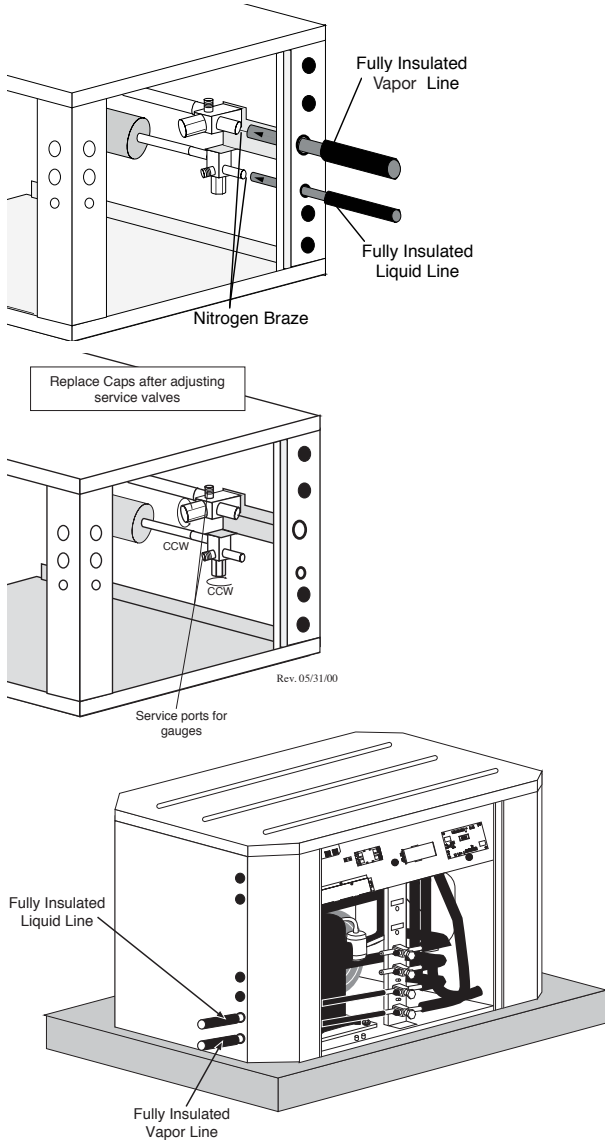

Table 6: Service Valve Positions

Position	Description	System	Service Port
CCW - Full Out	Operation Position	Open	Closed
CCW - Full Out 1/2 turn CW	Service Position	Open	Open
CCW - Full In	Shipping Position	Closed	Open

Re-Using Existing Line Set - R-22 to HFC-410A Conversion

New line sets are always recommended, but are required if;

- The previous system had a compressor burn out.
- The existing line set has oil traps.
- The existing line set is larger or smaller than the recommended line set for the HFC-410A system.
- The existing line set is damaged, corroded, or shows signs of abrasion/fatigue

Figure 10: Air Coil Connection

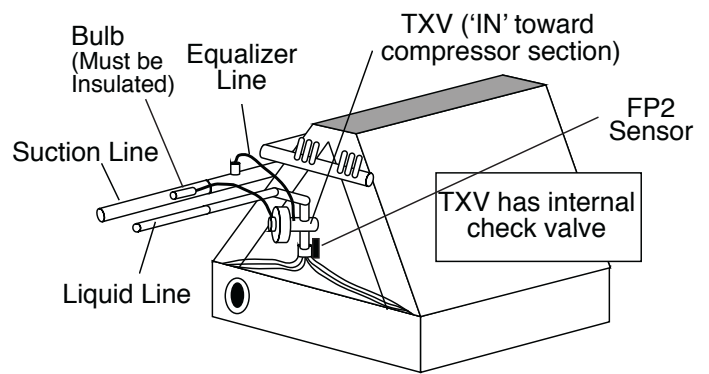

⚠ WARNING! ⚠

WARNING! If at all possible, it is recommended that a new line set be used when replacing an existing R-22 system with an HFC-410A system. In rare instances where replacing the line set is not possible, the line set must be flushed prior to installation of the HFC-410A system. It is also important to empty all existing traps. Polyolester (POE) oils are used in units charged with HFC-410A refrigerant. Residual mineral oil can act as an insulator on the wall of the coil tubing, hindering proper heat transfer and thus reducing system efficiency and capacity. Another important reason to thoroughly flush the line set is remove any trash and other contaminants that may be present which could clog the thermal expansion valve. Failure to properly flush the system per the instructions below will void the warranty.

⚠ WARNING! ⚠

WARNING! The Environmental Protection Agency prohibits the intentional venting of HCFC and HFC refrigerants during maintenance, service, repair and disposal of appliance. Approved methods of recovery, recycling or reclaiming must be followed.

⚠ CAUTION! ⚠

CAUTION! This procedure should not be performed on systems which contain containments (Example: compressor burn out).

Required Equipment

The following equipment will be required in order to flush the indoor coil and existing line set:

- Two R-22 recovery cylinders
- Refrigerant recovery machine with a pump down feature
- Two sets of gauges (one used for R-22 and one used with the HFC-410A).
- Cylinder of clean R-22 (minimum amount required to adequately flush shown below)

Refrigeration Installation

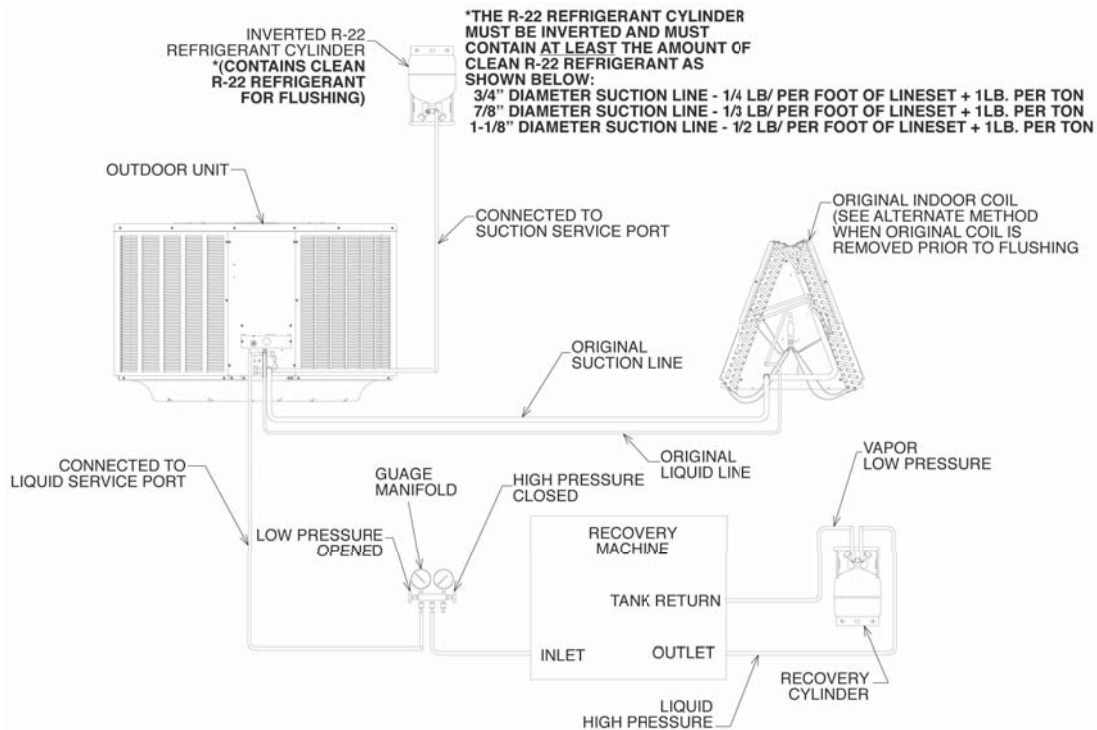

- 3/4" diameter suction lines: 1/4 lb. per foot of line set + 1 lb. per ton for indoor coil.
- 7/8" diameter suction lines: 1/3 lb. per foot of line set + 1 lb. per ton for indoor coil
- 1-1/8" diameter suction lines: 1/2 lb. per foot of line set + 1 lb. per ton for indoor coil.

Example: 3-ton system with 40 ft. long line set and 3/4" suction line.
 Line set: 1/4 lb./ft. x 40 ft. = 10 lb.
 Indoor coil: 1 lb./ton x 3 tons = 3 lbs. (not required if coil is removed and lines are connected together)
 Total: 10 lbs. + 3 lbs. = 13 lbs. to adequately flush line set and indoor coil.

The Flushing Procedure

1. Remove the existing R-22 refrigerant by selecting the appropriate procedure stated below.

If the unit is not operational, follow steps A-E.

- A.) First, disconnect all power supply to the existing outdoor unit.
- B.) Connect a clean refrigerant recovery cylinder and the refrigerant recovery machine to the existing unit according to the instructions provided with the recovery machine.
- C.) Remove all R-22 refrigerant from the existing system.
- D.) Check the gauges after shutdown to confirm all refrigerant has been completely removed from the entire system.
- E.) Disconnect the liquid and vapor lines from the existing outdoor unit.

If the unit is operational, follow steps F- L.

- F.) First, start the existing R-22 system in the cooling mode and close the liquid line valve.
 - G.) Completely pump all existing R-22 refrigerant into the outdoor unit. It will be necessary to bypass the low pressure switch if the unit is so equipped to ensure that the refrigerant is completely evacuated.)
 - H.) The low side system pressures will eventually reach 0 psig. When this happens, close the vapor line valve and immediately shut the outdoor unit off.
 - I.) Check the gauges after shutdown to confirm that the valves are not allowing refrigerant to leak back into the low side of the system.
 - J.) Disconnect power to the indoor furnace or air-handler to kill low voltage to the outdoor unit.
 - K.) Disconnect the power supply wiring from the existing outdoor unit.
 - L.) Unswear the liquid and vapor lines from the existing outdoor unit.
2. Remove the existing outdoor unit.
 3. Set the new HFC-410A unit in place and braze the liquid and vapor lines to the unit connections. Connect the low voltage and line voltage to the new outdoor unit. Do not turn on power supply to the unit and do not open the outdoor unit service valves at this time.
 4. The indoor coil can be left in place for the flushing process or removed.
 5. If the indoor coil is removed, the suction and liquid line must be connected together on the indoor coil end. See illustration for recommended method for connecting these together.
 6. If the indoor coil is left in place during flushing, removing

Refrigeration Installation

the existing refrigerant flow control orifice or thermal expansion valve prior to flushing is highly recommended to assure proper flushing. Use a field-provided fitting or piece of copper tubing to reconnect the lines where the thermal expansion valve was removed.

7. Remove the pressure tap valve cores from the outdoor unit's service valves.
8. Connect an R-22 cylinder of clean R-22 refrigerant to the vapor service valve. (see "Required Equipment Section" for minimum required amount of R-22 for adequate flushing)
9. Connect the low pressure side of an R-22 gauge set to the liquid line valve.
10. Connect a hose from the recovery machine with an empty recovery drum to the common port of the gauge set.
11. Set the recovery machine for liquid recovery and start the machine.
12. Open the gauge set low side valve. This will allow the recovery machine to pull a vacuum on the existing system line set.
13. Make sure to invert the cylinder of clean R-22 refrigerant and open the cylinder's valve to allow liquid refrigerant to flow into the system through the vapor line valve. (This should allow the refrigerant to flow from the cylinder and through the line set before it enters the recovery machine.) The cylinder should not be inverted if it is the type with separate liquid and vapor valves. Use the liquid valve on the cylinder in this case, keeping the cylinder upright.
14. Once the liquid refrigerant has been completely recovered, switch the recovery machine to vapor recovery so that the R-22 vapor can be completely recovered.

IMPORTANT! Always remember, every time the system is flushed you must always pull a vacuum with a recovery machine on the system at the end of each procedure. (If desired, a second flushing with clean refrigerant may be performed if insufficient amounts of mineral oil were removed during the initial flush.)

15. Tightly close the valve on the inverted R-22 cylinder and the gauge set valves.
16. Completely pump all remaining R22 refrigerant out of the recovery machine and turn the machine off.
17. Before removing the recovery machine, R-22 refrigerant cylinder and gauges, break the vacuum on the refrigerant lines and indoor coil using dry-nitrogen.
18. Unsweat the liquid and vapor lines from the old indoor coil or from each other and install a new matched HFC-410A indoor coil, connecting the flushed refrigerant lines to the new coil using field supplied connectors and tubing.
19. Reinstall pressure tap valve cores into unit service valves.
20. Pressurize the lines and coil and check for leaks in the line set connection points using a soap solution.
21. Thoroughly evacuate the line set and indoor coil per the instructions found in this manual.
22. Open the liquid and vapor service valves, releasing the HFC-410A refrigerant contained in the outdoor unit into the evacuated line set and indoor coil.
23. Energize the system and adjust the refrigerant charge according to the charging procedures found in this manual.

ALTERNATE METHOD

ORIGINAL LIQUID LINE OR
LIQUID LINE EXTENSION
WITH 180° BEND

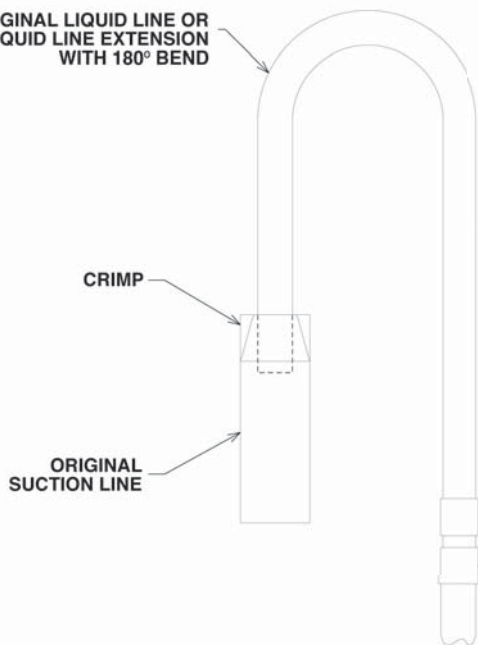

DEPENDING ON LINE CONFIGURATION, CHOOSE THE APPROPRIATE OPTION BELOW (1A OR 1B) WHICH BEST FITS THE SYSTEM.

1A. PULL AND MAKE A 180° BEND IN THE ORIGINAL LIQUID LINE AND FEED INTO ORIGINAL SUCTION LINE. MAKE SURE IT IS INSERTED DEEP ENOUGH TO AVOID PLUGGING DURING BRAZING. PROCEED TO STEP 5.

OR

1B. OBTAIN APPROPRIATE SIZED COUPLING FOR ORIGINAL LIQUID LINE, IF EXTENSION IS REQUIRED.

2. USING SAME SIZED COPPER TUBING AS THE ORIGINAL LIQUID LINE, BRAZE EXTENSION TO COUPLING.

3. BRAZE COUPLING TO ORIGINAL LIQUID LINE.

4. FEED OPPOSITE END OF LIQUID LINE EXTENSION INTO ORIGINAL SUCTION LINE. MAKE SURE IT IS INSERTED DEEP ENOUGH TO AVOID PLUGGING DURING BRAZING.

5. CRIMP ORIGINAL SUCTION LINE ONTO ORIGINAL LIQUID LINE OR EXTENSION.

6. BRAZE CRIMP SHUT.

7. USE TUBING CUTTER TO CUT TUBES.

Refrigeration Installation

FP2 Sensor Installation

An FP2 sensor with violet wiring is shipped loose with the compressor section. This is the air coil low temperature protection sensor. Install this sensor on the refrigerant line between the indoor expansion valve and the air coil using thermal compound and the supplied mounting clips. Ensure that the sensor makes good thermal contact with the refrigerant line and insulate the sensor.

Air coil low temperature protection will not be active if this sensor is installed incorrectly or is not installed.

Add-On Heat Pump Applications

The indoor coil should be located in the supply side of the furnace to avoid condensation damage to the furnace heat exchanger for add-on heat pump applications. A high temperature limit switch should be installed as shown in Figure 11b just upstream of the coil to de-energize the compressor any time the furnace is energized to avoid blowing hot air directly into the coil, elevating refrigerant pressures during operation. The heat pump will trip out on high pressure lockout without some method of disengaging the compressor during furnace operation. Alternatively, some thermostats with “dual fuel” mode will automatically de-energize the compressor when second stage (backup) heat is required.

The TXV should be brazed into place as shown in Figure 10, keeping the “IN” side toward the compressor section. The TXV has an internal check valve and must be installed in the proper direction for operation. Always keep the valve body cool with a brazing shield and wet rags to prevent damage to the TXV. Attach the bulb to the suction line using the supplied hose clamp. Be careful not to overtighten the clamp and deform the bulb.

NOTICE! The air coil should be thoroughly washed with a filming agent, (dishwasher detergent like Cascade) to help condensate drainage. Apply a 20 to 1 solution of detergent and water. Spray both sides of coil, repeat and rinse thoroughly with water.

Evacuation and Charging the Unit

LEAK TESTING - The refrigeration line set must be pressurized and checked for leaks before evacuating and charging the unit. To pressurize the line set, attach refrigerant gauges to the service ports and add an inert gas (nitrogen or dry carbon dioxide) until pressure reaches 60-90 psig [413-620 kPa]. Never use oxygen or acetylene to pressure test. Use a halogen leak tester or a good quality bubble solution to detect leaks on all connections made in the field. Check the service valve ports and stem for leaks. If a leak is found, repair it and repeat the above steps. For safety reasons do not pressurize system above 150 psig [1034 kPa]. System is now ready for evacuation and charging. Turn service valves full out CCW (see Table 6) and then turn back in one-half turn to open service ports. Add the required refrigerant so that the total charge calculated for the unit and line set is now in the system. Open the service valve

fully counter clockwise so that the stem will backseat and prevent leakage through the schrader port while it is not in use. Start unit in the heating mode and measure superheat and subcooling values after 5 minutes of run time. See tables 14d for superheat and sub-cooling values. Superheat is measured using suction temperature and pressure at the compressor suction line. Subcooling should be measured using the liquid line temperature immediately outside the compressor section cabinet and either the liquid line service valve pressure or the compressor discharge pressure. Note that different values from tables 14d will be obtained due to the pressure losses through the condenser heat exchanger. Adding refrigerant will increase sub-cooling while superheat should remain fairly constant allowing for a slight amount of hunting in TXV systems. This increase in subcooling will require 5 minutes or so of operation before it should be measured. After values are measured, compare to the chart and go to “FINAL EVALUATION.”

PARTIAL CHARGE METHOD - Open service valve fully counterclockwise and then turn back in one-half turn to open service port. Add vaporized (Gas) into the suction side of the compressor until the pressure in the system reaches approximately 100-120 psig. Never add liquid refrigerant into the suction side of a compressor. Start the unit in heating and add gas to the suction port at a rate not to exceed five pounds [2.27 kg] per minute. Keep adding refrigerant until the complete charge has been entered. Superheat is measured using suction temperature and pressure at the compressor suction line. Subcooling should be measured using the liquid line temperature immediately outside the compressor section cabinet and either the liquid line service valve pressure or the compressor discharge pressure. Note that different values from tables 14d will be obtained due to the pressure losses through the condenser heat exchanger. Adding refrigerant will increase sub-cooling while superheat should remain fairly constant allowing for a slight amount of hunting in TXV systems. This increase in subcooling will require 5 minutes or so of operation before it should be measured. After values are measured, compare to the chart and go to “FINAL EVALUATION.”

FINAL EVALUATION -In a split system, cooling subcooling values can be misleading depending on the location of the measurement. Therefore, it is recommended that charging be monitored in the heating mode. Charge should be evaluated by monitoring the subcooling in the heating mode. After initial check of heating sub-cooling, shut off unit and allow to sit 3-5 minutes until pressures equalize. Restart unit in the cooling mode and check the cooling superheat against Tables 14d. If unit runs satisfactorily, charging is complete. If unit does not perform to specifications the cooling TXV (air coil side) may need to be readjusted (if possible) until the cooling superheat values are met.

Checking Superheat and Subcooling

Determining Superheat:

1. Measure the temperature of the suction line at a point

Refrigeration Installation

- near the expansion valve bulb.
- Determine the suction pressure by attaching refrigeration gauges to the suction schrader connection at the compressor.
 - Convert the pressure obtained in step 2 to saturation temperature (boiling point) by using the pressure/temperature conversion table on the gauge set.
 - Subtract the temperature obtained in step 3 from step 1. The difference will be the superheat of the unit or the total number of degrees above saturation temperature. Refer to Tables 14d for superheat ranges at specific entering water conditions.

Example:

The temperature of the suction line at the sensing bulb is 50°F. The suction pressure at the compressor is 110 psig which is equivalent to 36°F saturation temperature from the R-410A press/temp conversion table on the gauge set. 36°F subtracted from 50°F = 14°F Superheat.

Determining Sub-Cooling:

- Measure the temperature of the liquid line on the smaller refrigerant line (liquid line) just outside of the cabinet. This location will be adequate for measurement in both modes unless a significant temperature drop in the liquid line is anticipated.
- Determine the condenser pressure (high side) by attaching refrigerant gauges to the schrader connection on the liquid line service valve. If the hot gas discharge line of the compressor is used, refer to the appropriate column in Tables 14d.
- Convert the pressure obtained in step 2 to the saturation temperature by using the press/temp conversion table on the gauge set.
- Subtract the temperature of Step 3 from the temperature of Step 1. The difference will be the sub-cooling value for that unit (total degrees below the saturation temperature). Refer to Tables 14a to 14d for sub-cooling values at specific entering water temperatures.

Example:

The condenser pressure at the service port is 335 psig, which is equivalent to 104°F saturation temperature. Discharge pressure is 365 psig at the compressor (109°F saturation temperature). Measured liquid line temperature is 100°F. 100°F subtracted from 104°F = 4 degrees sub-cooling (9 degrees if using the compressor discharge pressure).

Refrigeration Installation

Figure 11a: Typical Split/Air Handler Installation

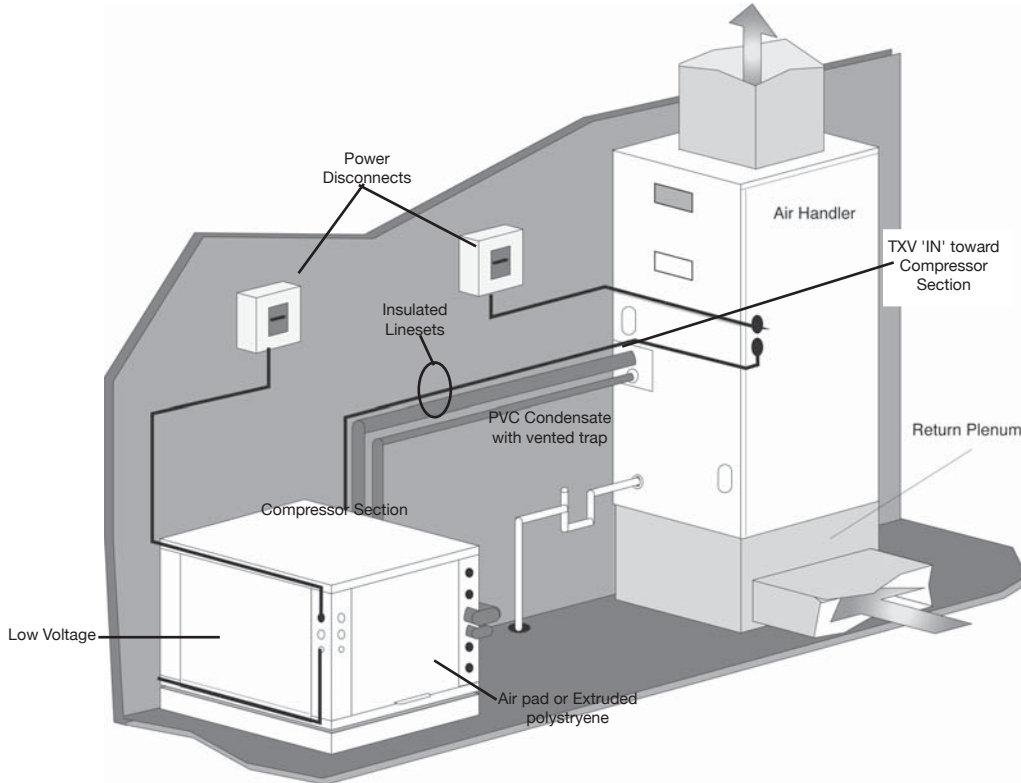
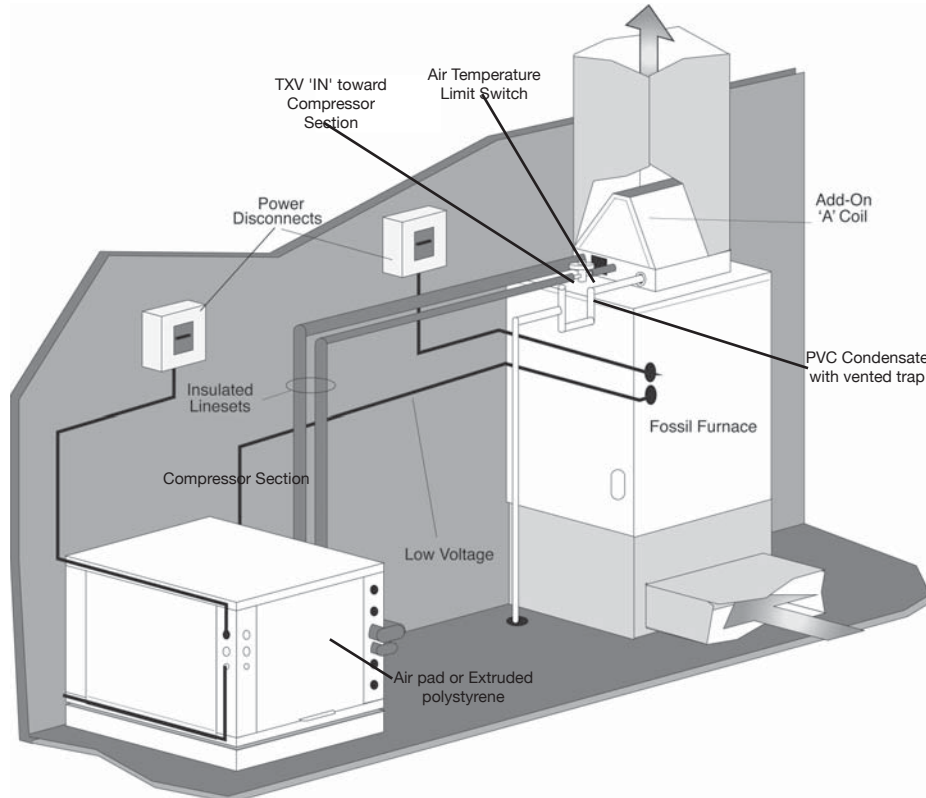

Figure 11b: Typical Split/Add-on Coil Fossil Fuel Furnace Installation



Refrigeration Installation

Evacuation Of The Lineset And Coil

The line set and coil must be evacuated to at least 500 microns to remove any moisture and noncondensables. Evacuate the system through both service ports in the shipping position (full CW in - see table 6) to prevent false readings on the gauge because of pressure drop through service ports. A vacuum gauge or thermistor capable of accurately measuring the vacuum depth is crucial in determining if the system is ready for charging. If the system meets the requirements in Figure 12, it is ready for charging.

Figure 12: Evacuation Graph

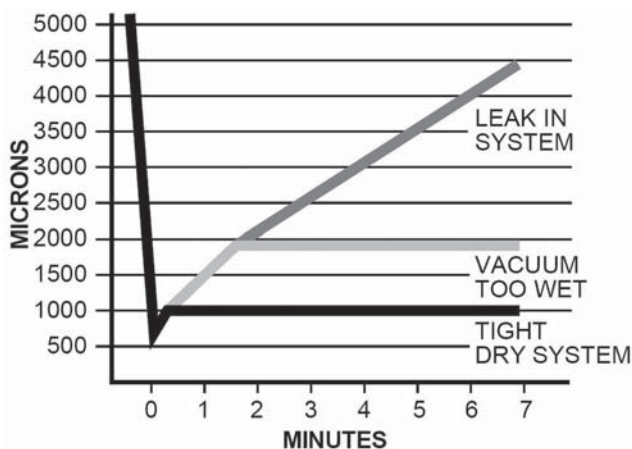

▲ NOTICE! ▲

NOTICE: Use tables 16a to 16d for superheat/subcooling values. These tables use discharge pressure (converted to saturation temperature) and liquid line temperature for subcooling calculations. If using liquid line pressure, subtract 3°F from the table values.

Charging The System

There are two methods of charging a refrigerant system. One method is the total charge method, where the volume of the system is determined and the refrigerant is measured and added into the evacuated system. The other method is the partial charge method where a small initial charge is added to an evacuated system, and remaining refrigerant added during operation.

Total Charge Method - See Table 5 for the compressor section basic charge. For line sets with 3/8" liquid lines add 0.6 ounces of refrigerant to the basic charge for every installed foot of liquid line [0.6 grams per cm]. Add 1.2 oz. per foot [1.1 grams per cm] if using 1/2" line. Once the total charge is determined, the factory pre-charge (Table 5) is subtracted and the remainder is the amount needed to be added to the system. This method should be used with the AHRI matched air handler.

EXAMPLE: Model 049 with 40 feet [12 meters] of installed liquid line (3/8" O.D.). The basic charge of model 049 is 111 oz [3.15 kg]. The 40 ft. [12 meter] 3/8" line set requires 24 oz. [0.72 kg] (40 ft. x 0.6 oz./ft = 24 oz. -- 1200cm x 0.6g/cm = 720g). Total charge = 111 + 24 = 135 oz [3.15 + 0.72 = 3.87 kg]. The compressor section is shipped from the factory with 126 oz. [3.57 kg] of refrigerant (for 25 ft [7.6m] lineset), so the amount to be added is 9 oz. [0.29 kg] (total charge - shipped charge = charge to be added).

Hot Water Generator

The HWG (Hot Water Generator) or desuperheater option provides considerable operating cost savings by utilizing excess heat energy from the heat pump to help satisfy domestic hot water requirements. The HWG is active throughout the year, providing virtually free hot water when the heat pump operates in the cooling mode or hot water at the COP of the heat pump during operation in the heating mode. Actual HWG water heating capacities are provided in the appropriate heat pump performance data.

Heat pumps equipped with the HWG option include a built-in water to refrigerant heat exchanger that eliminates the need to tie into the heat pump refrigerant circuit in the field. The control circuit and pump are also built in for residential equipment. Figure 13 shows a typical example of HWG water piping connections on a unit with built-in circulating pump. This piping layout reduces scaling potential.

The temperature set point of the HWG is field selectable to 125°F or 150°F. The 150°F set point allows more heat storage from the HWG. For example, consider the amount of heat that can be generated by the HWG when using the 125°F set point, versus the amount of heat that can be generated by the HWG when using the 150°F set point.

In a typical 50 gallon two-element electric water heater the lower element should be turned down to 100°F, or the lowest setting, to get the most from the HWG. The tank will eventually stratify so that the lower 80% of the tank, or 40 gallons, becomes 100°F (controlled by the lower element). The upper 20% of the tank, or 10 gallons, will be maintained at 125°F (controlled by the upper element).

Using a 125°F set point, the HWG can heat the lower 40 gallons of water from 100°F to 125°F, providing up to 8,330 btu's of heat. Using the 150°F set point, the HWG can heat the same 40 gallons of water from 100°F to 150°F and the remaining 10 gallons of water from 125°F to 150°F, providing

Figure 13: Typical HWG Installation (Indoor Compressor Section)

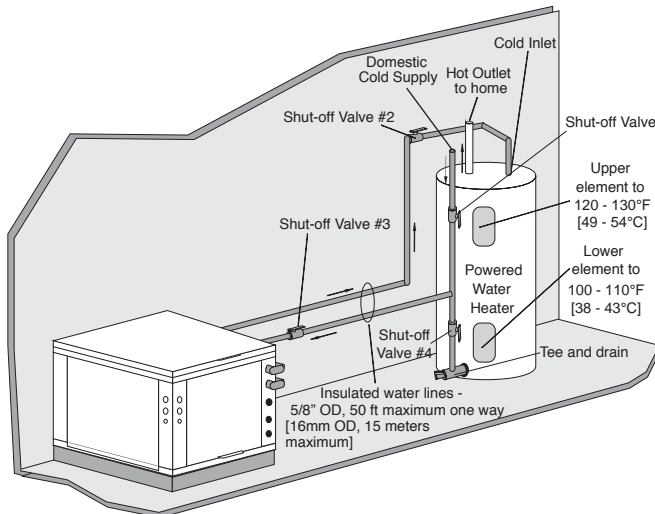

a total of up to 18,743 btu's of heat, or more than twice as much heat as when using the 125°F set point.

This example ignored standby losses of the tank. When those losses are considered the additional savings are even greater.

Electric water heaters are recommended. If a gas, propane, or oil water heater is used, a second preheat tank must be installed (Figure 14). If the electric water heater has only a single center element, the dual tank system is recommended to insure a usable entering water temperature for the HWG.

Typically a single tank of at least 52 gallons (235 liters) is used to limit installation costs and space. However, a dual tank, as shown in Figure 14, is the most efficient system, providing the maximum storage and temperate source water to the HWG.

It is always advisable to use water softening equipment on domestic water systems to reduce the scaling potential and lengthen equipment life. In extreme water conditions, it may be necessary to avoid the use of the HWG option since the potential cost of frequent maintenance may offset or exceed any savings. Consult Table 4 for scaling potential tests.

⚠ WARNING! ⚠

WARNING! A 150°F SETPOINT MAY LEAD TO SCALDING OR BURNS. THE 150°F SET POINT MUST ONLY BE USED ON SYSTEMS THAT EMPLOY AN APPROVED ANTI-SCALD VALVE.

Figure 14: HWG Double Tank Installation (Indoor Compressor Section)

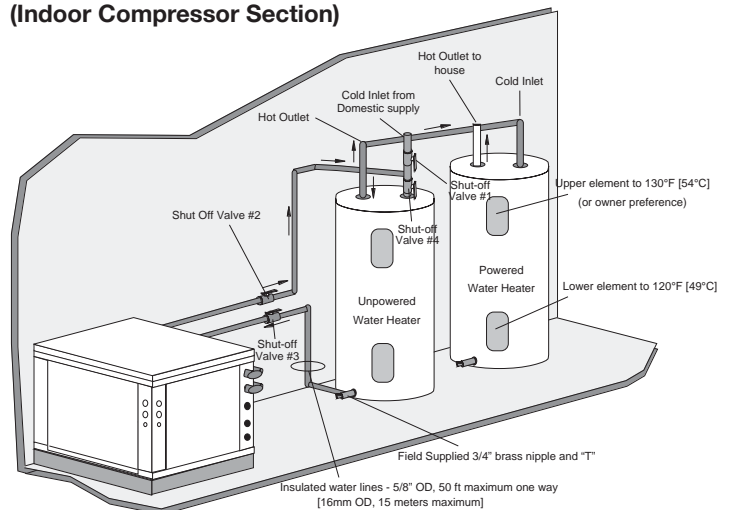

Hot Water Generator

Installation

The HWG is controlled by two sensors and a microprocessor control. One sensor is located on the compressor discharge line to sense the discharge refrigerant temperature. The other sensor is located on the HWG heat exchanger's "Water In" line to sense the potable water temperature.

⚠ WARNING! ⚠

WARNING! UNDER NO CIRCUMSTANCES SHOULD THE SENSORS BE DISCONNECTED OR REMOVED AS FULL LOAD CONDITIONS CAN DRIVE HOT WATER TANK TEMPERATURES FAR ABOVE SAFE TEMPERATURE LEVELS IF SENSORS HAVE BEEN DISCONNECTED OR REMOVED.

The microprocessor control monitors the refrigerant and water temperatures to determine when to operate the HWG. The HWG will operate any time the refrigerant temperature is sufficiently above the water temperature. Once the HWG has satisfied the water heating demand during a heat pump run cycle, the controller will cycle the pump at regular intervals to determine if an additional HWG cycle can be utilized. The microprocessor control includes 3 DIP switches, SW10 (HWG PUMP TEST), SW11 (HWG TEMP), and SW12 (HWG STATUS).

SW10 HWG PUMP TEST. When this switch is in the "ON" position, the HWG pump is forced to operate even if there is no call for the HWG. This mode may be beneficial to assist in purging the system of air during initial start up. When SW10 is in the "OFF" position, the HWG will operate normally. This switch is shipped from the factory in the "OFF" (normal) position. **NOTE;** If left in the "On" position for 5 minutes, the pump control will revert to normal operation.

SW11 HWG TEMP. The control setpoint of the HWG can be set to either of two temperatures, 125°F or 150°F. When SW11 is in the "ON" position the HWG setpoint is 150°F. When SW11 is in the "OFF" position the HWG setpoint is

⚠ WARNING! ⚠

WARNING! USING A 150°F SETPOINT ON THE HWG WILL RESULT IN WATER TEMPERATURES SUFFICIENT TO CAUSE SEVERE PHYSICAL INJURY IN THE FORM OF SCALDING OR BURNS, EVEN WHEN THE HOT WATER TANK TEMPERATURE SETTING IS VISIBLY SET BELOW 150°F. THE 150°F HWG SETPOINT MUST ONLY BE USED ON SYSTEMS THAT EMPLOY AN APPROVED ANTI-SCALD VALVE (CLIMATEMASTER PART NUMBER AVAS4) AT THE HOT WATER STORAGE TANK WITH SUCH VALVE PROPERLY SET TO CONTROL WATER TEMPERATURES DISTRIBUTED TO ALL HOT WATER OUTLETS AT A TEMPERATURE LEVEL THAT PREVENTS SCALDING OR BURNS!

Figure 15:

ANTI-SCALD VALVE PIPING CONNECTIONS

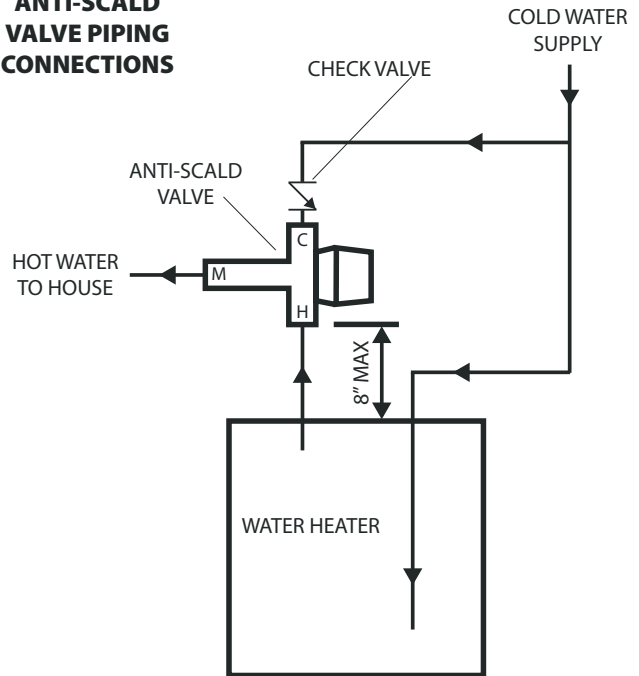

125°F. This switch is shipped from the factory in the "OFF" (125°F) position.

SW12 HWG STATUS. This switch controls operation of the HWG. When SW12 is in the "ON" position the HWG is disabled and will not operate. When SW12 is in the "OFF" position the HWG is in the enabled mode and will operate normally. This switch is shipped from the factory in the "OFF" (disabled) position. **CAUTION: DO NOT PLACE THIS SWITCH IN THE ENABLED POSITION UNTIL THE HWG PIPING IS CONNECTED, FILLED WITH WATER, AND PURGED OR PUMP DAMAGE WILL OCCUR.**

When the control is powered and the HWG pump output is not active, the status LED (AN1) will be "On". When the HWG pump output is active for water temperature sampling or HWG operation, the status LED will slowly flash (On 1 second, Off 1 second).

If the control has detected a fault, the status LED will flash a numeric fault code as follows:

Hot Water Sensor Fault	1 flash
Compressor Discharge sensor fault	2 flashes
High Water Temperature (>160°F)	3 flashes
Control Logic Error	4 flashes

Fault code flashes have a duration of 0.4 seconds with a 3 second pause between fault codes. For example, a "Compressor Discharge sensor fault" will be four flashes 0.4 seconds long, then a 3 second pause, then four flashes again, etc.

Hot Water Generator

Warning! The HWG pump is fully wired from the factory. Use extreme caution when working around the microprocessor control as it contains line voltage connections that presents a shock hazard that can cause severe injury or death!

The heat pump, water piping, pump, and hot water tank should be located where the ambient temperature does not fall below 50°F [10°C]. Keep water piping lengths at a minimum. DO NOT use a one way length greater than 50 ft. (one way) [15 m]. See Table 7 for recommended piping sizes and maximum lengths.

All installations must be in accordance with local codes. The installer is responsible for knowing the local requirements, and for performing the installation accordingly. DO NOT energize the pump until “water tank refill” section, below is completed. Powering the pump before all installation steps are completed may damage the pump.

Water Tank Preparation

1. Turn off power or fuel supply to the hot water tank.
2. Connect a hose to the drain valve on the water tank.
3. Shut off the cold water supply to the water tank.
4. Open the drain valve and open the pressure relief valve or a hot water faucet to drain tank.
5. When using an existing tank, it should be flushed with cold water after it is drained until the water leaving the drain hose is clear and free of sediment.
6. Close all valves and remove the drain hose.
7. Install HWG water piping.

HWG Water Piping

1. Using at least 5/8” [16mm] O.D. copper, route and install the water piping, valves and air vent as shown in Figures 13 or 14. Install an approved anti-scald valve if the 150°F HWG setpoint is or will be selected. An appropriate method must be employed to purge air from the HWG piping. This may be accomplished by flushing water through the HWG (as In Figures 13 and 14) or by installing an air vent at the high point of the HWG piping system.
2. Insulate all HWG water piping with no less than 3/8” [10mm] wall closed cell insulation.
3. Open both shut off valves and make sure the tank drain valve is closed.

Water Tank Refill

1. Close valve #4. Ensure that the HWG valves (valves #2 and #3) are open. Open the cold water supply (valve #1) to fill the tank through the HWG piping. This will purge air from the HWG piping.
2. Open a hot water faucet to vent air from the system until water flows from faucet; turn off faucet. Open valve #4.
3. Depress the hot water tank pressure relief valve handle to ensure that there is no air remaining in the tank.
4. Inspect all work for leaks.
5. Before restoring power or fuel supply to the water heater, adjust the temperature setting on the tank thermostat(s)

- to insure maximum utilization of the heat available from the refrigeration system and conserve the most energy. On tanks with both upper and lower elements and thermostats, the lower element should be turned down to 100°F [38°C] or the lowest setting; the upper element should be adjusted to 120-130°F [49-54°C]. Depending upon the specific needs of the customer, you may want to adjust the upper element differently. On tanks with a single thermostat, a preheat tank should be used (Fig 14).
6. Replace access cover(s) and restore power or fuel supply.

Initial Start-Up

1. Make sure all valves in the HWG water circuit are fully open.
2. Turn on the heat pump and allow it to run for 10-15 minutes.
3. Set SW12 to the “OFF” position (enabled) to engage the HWG.
4. The HWG pump should not run if the compressor is not running.
5. The temperature difference between the water entering and leaving the HWG coil should be approximately 5-10°F [3-6°C].
6. Allow the unit to operate for 20 to 30 minutes to insure that it is functioning properly.

Table 7: HWG Water Piping Size and Length

Unit Nominal Tonnage	Nominal HWG Flow (gpm)	1/2" Copper (max length*)	3/4" Copper (max length*)
1.5	0.6	50	-
2.0	0.8	50	-
2.5	1.0	50	-
3.0	1.2	50	-
3.5	1.4	50	-
4.0	1.6	45	50
5.0	2.0	25	50
6.0	2.4	10	50

*Maximum length is equivalent length one way of type L copper.

Hot Water Generator Module Refrigeration Installation For Outdoor Compressor Section Only

General Information

The HWG Module consists of an all-copper, vented double-wall heat exchanger and a water-cooled water circulating pump. The pump is controlled by a microprocessor in the HWG module. Power for the pump is provided from a remote 115 vac power source.

Location/Mounting

The HWG module should be mounted as close to the heat pump outdoor section as possible, in order to minimize the length of refrigerant run. Indoor mounting is preferred, where practical, to reduce the likelihood of freezing ambient temperature. It is recommended that the HWG module be mounted above the system compressor in order to promote proper oil movement and drain-down. **This means that the HWG module can be wall mounted in any orientation except for stubs up.** Mounting should be accomplished by fastening the HWG module cabinet to the wall or other selected vertical surface. Mounting holes are provided at the rear of the unit. Any fastener suitable for supporting a 12 pound [5.4] vertical load is acceptable.

The HWG, water piping and hot water tank should be located where the ambient temperature does not fall below 50°F [10°C]. Keep water piping lengths at a minimum. DO NOT use a one-way length greater than 50 ft. (one way) [15 m]. See Table 7 for maximum water piping lengths.

All installations must be in accordance with local codes. The installer is responsible for knowing the local requirements, and for performing the installation accordingly

SPECIAL NOTE: The selected mounting location and orientation must allow the circulator pump to be positioned with the motor shaft horizontal. **DO NOT install the Heat Recovery Unit flat on its back.**

Refrigerant Line Installation

Before starting the installation into the refrigerant circuit, inspect and note the condition and performance of the heat pump. Disconnect power to the heat pump outdoor unit. Any system deficiencies must be corrected prior to installing the HWG module. Addition of the unit will not correct system problems. Record the suction and discharge pressures and compressor amperage draw. These will be used for comparison with system operation after the refrigerant line installation is complete and before the water line installation is performed.

Install the Add-On HWG Kit

Locate the HWG as close to the water heater as possible. Install the lineset to the desuperheater valves in the outdoor compressor section and the refrigerant line connections on the HWG. Maximum length should be 30 feet one way. Evacuate the lineset to 500 microns through the hot gas valves in the outdoor unit. Open the HWG valves in the compressor section up fully (and close the desuperheater bypass valve). See Figures 16a through 16d. Check the lineset for

leaks. Verify that lineset tubing is completely insulated with a minimum 1/2" thick closed cell and painted to prevent deterioration of the insulation due to ultra violet light and weather. Make the connections with high temperature solder or brazing rod. The recommended refrigerant line size is dependent on the one way distance between the Heat Recovery Unit and the compressor; and the size of the system. Use Table 8 as a guideline.

Initial Start-Up

1. Make sure all valves in the HWG water circuit are fully open.
2. Turn the heat pump power and remote HWG power "off" and switch dip switch SW12 on the HWG controller to the "off" (enabled) position to activate the HWG.
3. The HWG pump should not run if the compressor is not running.
4. The temperature difference between the water entering and leaving the HWG should be approximately 5-10 °F [3-6 °C].
5. Allow the unit to operate for 20 to 30 minutes insure that it is functioning properly.
6. Always turn dip switch SW12 on the HWG controller to the "on" (disabled) position to deactivate the HWG when servicing the outdoor compressor section.

NOTICE! Make sure the compressor discharge line is connected to the "Hot Gas In" stub on the Heat Recovery Unit.

⚠ WARNING! ⚠

WARNING! The HWG module is an appliance that operates in conjunction with the heat pump system, the hot water system and the electrical system. Installation should only be performed by skilled technicians with appropriate training and experience. The installation must be in compliance with local codes and ordinances. Local plumbing and electrical building codes take precedence over instructions contained herein. The Manufacturer accepts no liability for equipment damaged and/or personal injury arising from improper installation of the HWG module.

⚠ CAUTION! ⚠

CAUTION! The HWG module must be installed in an area that is not subject to freezing temperatures.

⚠ CAUTION! ⚠

CAUTION! Locate Refrigerant lines to avoid accidental damage by lawnmowers or children.

Electrical - Line Voltage

⚠ WARNING! ⚠

WARNING! To avoid possible injury or death due to electrical shock, open the power supply disconnect switch and secure it in an open position during installation.

⚠ CAUTION! ⚠

CAUTION! Use only copper conductors for field installed electrical wiring. Unit terminals are not designed to accept other types of conductors.

Electrical - Line Voltage

All field installed wiring, including electrical ground, must comply with the National Electrical Code as well as all applicable local codes. Refer to the unit electrical data for fuse sizes. Consult wiring diagram for field connections that must be made by the installing (or electrical) contractor.

All final electrical connections must be made with a length of flexible conduit to minimize vibration and sound transmission to the building.

General Line Voltage Wiring

Be sure the available power is the same voltage and phase shown on the unit serial plate. Line and low voltage wiring must be done in accordance with local codes or the National Electric Code, whichever is applicable.

Power Connection

Line voltage connection is made by connecting the incoming line voltage wires to the "L" side of the contactor as shown in Figures 18 and 19. Consult Table 9a or 9b for correct fuse size.

208-230 Volt Operation

Verify transformer tap with air handler wiring diagram to insure that the transformer tap is set to the correct voltage, 208V or 230V.

Table 9a: TTS Series Electrical Data

Model	Compressor			HWG Pump FLA	External Pump FLA	Total Unit FLA	Min Circuit Amps	Max Fuse/HACR	Min AWG	Max Wire Ft. (m)
	RLA	LRA	Qty							
026	10.3	52.0	1	0.4	4.0	14.7	17.3	25	10	107 (32.7)
038	16.7	82.0	1	0.4	4.0	21.1	25.3	40	10	73 (22.3)
049	21.2	96.0	1	0.4	4.0	25.6	30.9	50	8	95 (29.2)
064	25.6	118.0	1	0.4	4.0	30.0	36.4	60	8	81 (24.8)

Rated Voltage of 208/230/60/1
HACR circuit breaker in USA only
Wire length based on one way measurement with 2% voltage drop

Min/Max Voltage of 197/254
All fuses Class RK-5
Wire size based on 60°C copper conductor and Minimum Circuit Ampacity.

Table 9b: TTP Series Electrical Data

Model	Compressor			Internal Loop Pump FLA	Total Unit FLA	Min Circuit Amps	Max Fuse/HACR	Min AWG	Max Wire Ft. (m)
	RLA	LRA	Qty						
025	10.3	52.0	1	0.8	11.1	13.7	20	12	85 (26)
036	16.7	82.0	1	0.8	17.5	21.7	35	10	85 (26)
048	21.2	96.0	1	1.6	22.8	28.1	45	8	105 (32)
062	25.6	118.0	1	1.6	27.2	33.6	50	8	88 (27)

Rated Voltage of 208/230/60/1
HACR circuit breaker in USA only
Wire length based on one way measurement with 2% voltage drop

Min/Max Voltage of 197/254
All fuses Class RK-5
Wire size based on 60°C copper conductor and Minimum Circuit Ampacity.

HWG Module	Voltage	Pump FLA	Total FLA	Min Circuit Amps	Min Wire Size
AHWG1AARS	115/60/1	0.52	0.52	1.20	14 ga.
AHWG1AGRS	208/230/60/1	0.40	0.40	0.90	14 ga.

Electrical - Power Wiring

Figure 18: Indoor Compressor Section Line Voltage Field Wiring

Unit Power Supply
 (see electrical table for wire
 and breaker size)

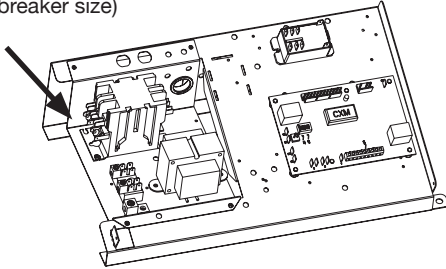
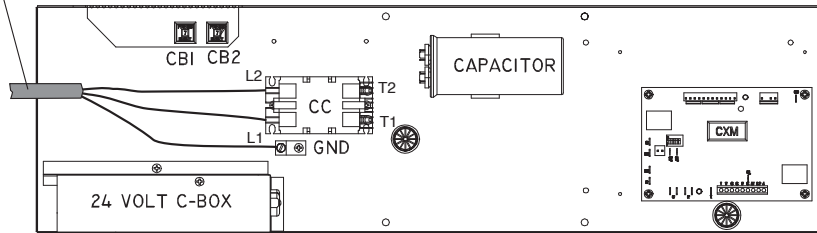

Figure 19: Outdoor Compressor Section Line Voltage Field Wiring

Consult Electrical Table for wire and fuse size.
 All power wiring per local code



ELECTRICAL - HWG WIRING

208-230 Volt Operation

Verify transformer tap with air handler wiring diagram to insure that the transformer tap is set to the correct voltage, 208V or 230V.

HWG Module Wiring - For “Outdoor” Compressor Section

The HWG module should be wired to a 115 vac power supply as shown in figure 20. A safety disconnect should be installed at the HWG module as required by code to allow servicing of the module. DO NOT energize the pump until all HWG piping is completed and air is purged from the water piping to avoid running the pump “dry”.

Figure 20: HWG Module Wiring - For Use with Outdoor Compressor Section

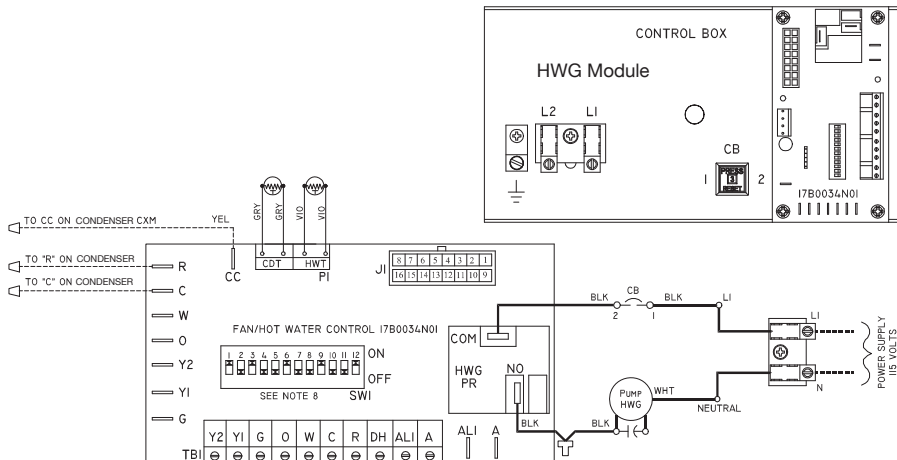

Electrical - Low Voltage Wiring

Thermostat Connections (Indoor Compressor Section)

The thermostat should be wired directly to the CXM board. Figure 21 show low voltage wiring. Note that the air handler or furnace transformer will be used to power the CXM board in the compressor section. See "Electrical – Thermostat" for specific terminal connections.

Figure 21: TTS Low Voltage Field Wiring

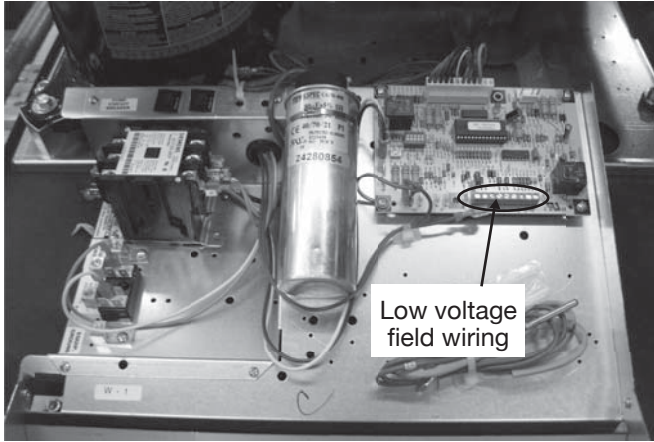

Thermostat Connections (Outdoor Compressor Section)

The thermostat should be wired through the air handler to the outdoor compressor section. Typical thermostat wiring is shown in Figure 22. Note that the air handler or furnace transformer will be used to power the CXM board in the compressor section.

Figure 22: TTP Low Voltage Field Wiring

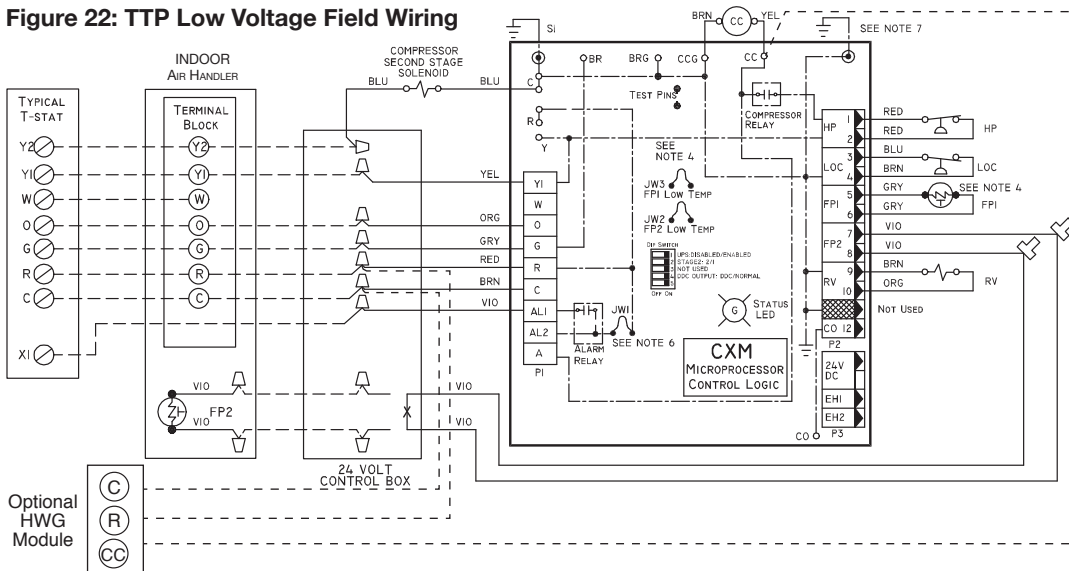

Low Air Temperature Sensor Installation

After mounting the FP2 sensor in the air handler connect the sensor wiring to the violet wires in the compressor section's control box as shown in Figure 22. Clip the violet wire loop in the compressor section's control box. Wire the violet leads from FP2 to the violet leads clipped in the control box. FP2 sensor is packed inside the compressor section control box.

Low Water Temperature Cutout Selection

The CXM control allows the field selection of low water (or water-antifreeze solution) temperature limit by clipping jumper JW3, which changes the sensing temperature associated with thermistor FP1. Note that the FP1 thermistor is located on the refrigerant line between the coaxial heat exchanger and expansion device (TXV). Therefore, FP1 is sensing refrigerant temperature, not water temperature, which is a better indication of how water flow rate/temperature is affecting the refrigeration circuit.

The factory setting for FP1 is for systems using water (30°F [-1.1°C] refrigerant temperature). In low water temperature (extended range) applications with antifreeze (most ground loops), jumper JW3 should be clipped as shown in Figure 23 to change the setting to 10°F [-12.2°C] refrigerant temperature, a more suitable temperature when using an antifreeze solution. All residential units include water/refrigerant circuit insulation to prevent internal condensation, which is required when operating with entering water temperatures below 59°F [15°C].

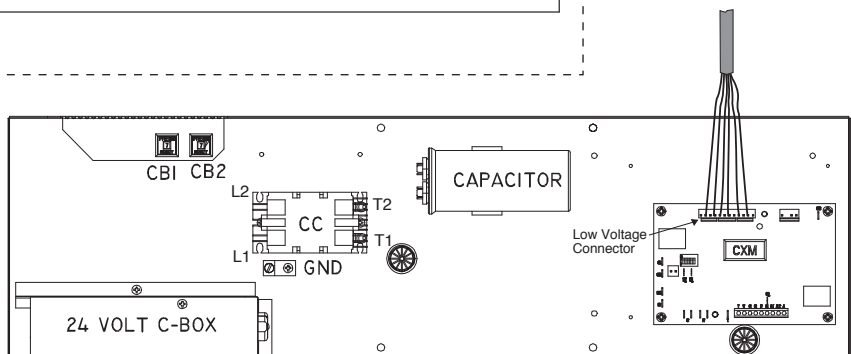

Electrical - Low Voltage Wiring

Figure 23: FP1 Limit Setting

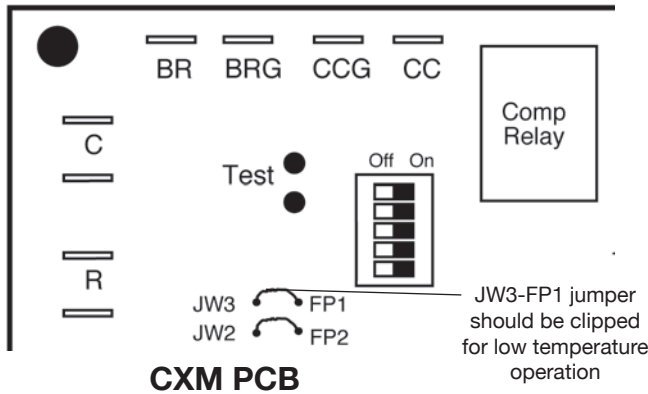

Accessory Connections

A terminal paralleling the compressor contactor coil has been provided on the CXM control. Terminal "A" is designed to control accessory devices, such as water valves. Note: This terminal should be used only with 24 Volt signals and not line voltage. Terminal "A" is energized with the compressor contactor. See Figure 24 or the specific unit wiring diagram for details.

Figure 24: Accessory Wiring

Terminal Strip

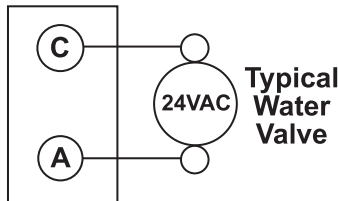

Water Solenoid Valves - "Indoor" Compressor Section Only

An external solenoid valve(s) should be used on ground water installations to shut off flow to the unit when the compressor is not operating. A slow closing valve may be required to help reduce water hammer. Figure 24 shows typical wiring for a 24VAC external solenoid valve. Figures 25 and 26 illustrate typical slow closing water control valve wiring for Taco 500 series (ClimateMaster P/N AVM...) and Taco SBV series valves. Slow closing valves take approximately 60 seconds to open (very little water will flow before 45 seconds). Once fully open, an end switch allows the compressor to be energized. Only relay or triac based electronic thermostats should be used with slow closing valves. When wired as shown, the slow closing valve will operate properly with the following notations:

1. The valve will remain open during a unit lockout.
2. The valve will draw approximately 25-35 VA through the "Y" signal of the thermostat.

Note: This valve can overheat the anticipator of an electromechanical thermostat. Therefore, only relay or triac based thermostats should be used.

Two-stage Units

Two-stage units should be designed with two parallel valves for ground water applications to limit water use during first stage operation. For example, at 1.5 gpm/ton [2.0 l/m per kW], a model 049 unit requires 6 gpm [23 l/m] for full load (2nd stage) operation, but only 4 gpm [15 l/m] during 1st stage operation. Since the unit will operate on first stage 80-90% of the time, significant water savings can be realized by using two parallel solenoid valves with two flow regulators. In the example above, stage one solenoid would be installed with a 4 gpm [15 l/m] flow regulator on the outlet, while stage two would utilize a 2 gpm [8 l/m] flow regulator. When stage one is operating, the second solenoid valve will be closed. When stage two is operating, both valves will be open, allowing full load flow rate.

Figure 27 illustrates piping for two-stage solenoid valves. Review figures 24-26 for wiring of stage one valve. Stage two valve should be wired between "Y2" (compressor solenoid -- wire nut connection) and terminal "C." **NOTE: When EWT is below 50°F [10°C], a minimum of 2 gpm per ton (2.6 l/m per kW) is required.**

Figure 25: AMV Valve Wiring

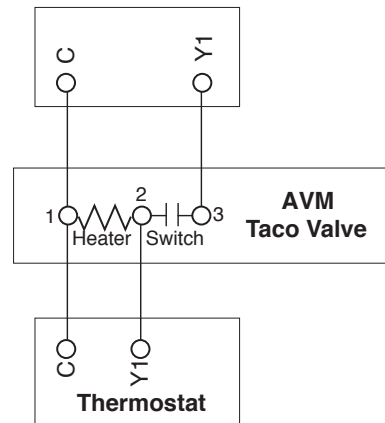
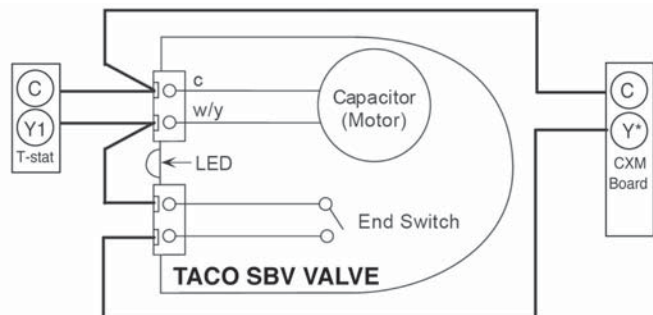
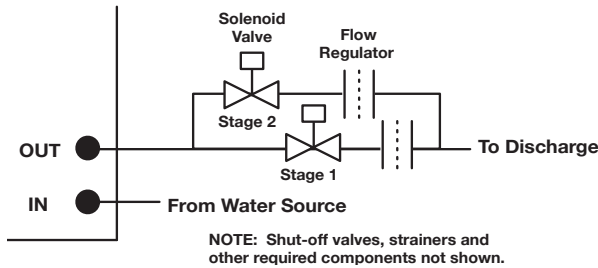

Figure 26: Taco SBV Valve Wiring



Electrical - Low Voltage Wiring

Figure 27: Two-Stage Piping



⚠ CAUTION! ⚠

CAUTION! Many units are installed with a factory or field supplied manual or electric shut-off valve. **DAMAGE WILL OCCUR** if shut-off valve is **closed** during unit operation. A high pressure switch must be installed on the heat pump side of any field provided shut-off valves and connected to the heat pump controls in series with the built-in refrigerant circuit high pressure switch to disable compressor operation if water pressure exceeds pressure switch setting. The field installed high pressure switch shall have a cut-out pressure of 300 psig and a cut-in pressure of 250 psig. This pressure switch can be ordered from ClimateMaster with a 1/4" internal flare connection as part number 39B0005N02.

ELECTRICAL - THERMOSTAT WIRING

Thermostat Installation

The thermostat should be located on an interior wall in a larger room, away from supply duct drafts. DO NOT locate the thermostat in areas subject to sunlight, drafts or on external walls. The wire access hole behind the thermostat may in certain cases need to be sealed to prevent erroneous temperature measurement. Position the thermostat back plate against the wall so that it appears level and so the thermostat wires protrude through the middle of the back plate. Mark the position of the back plate mounting holes and drill holes with a 3/16" (5mm) bit. Install supplied anchors and secure plate to the wall. Thermostat wire must be 18 AWG wire. Wire the appropriate thermostat as shown in Figures 28a and 28b to the low voltage terminal strip on the CXM control board. Practically any heat pump thermostat will work with these units, provided it has the correct number of heating and cooling stages.

⚠ CAUTION! ⚠

CAUTION! Refrigerant pressure activated water regulating valves should never be used with ClimateMaster equipment.

Figure 28a: Typical Thermostat Wiring, Single-Stage Units (2 Heat/1 Cool)

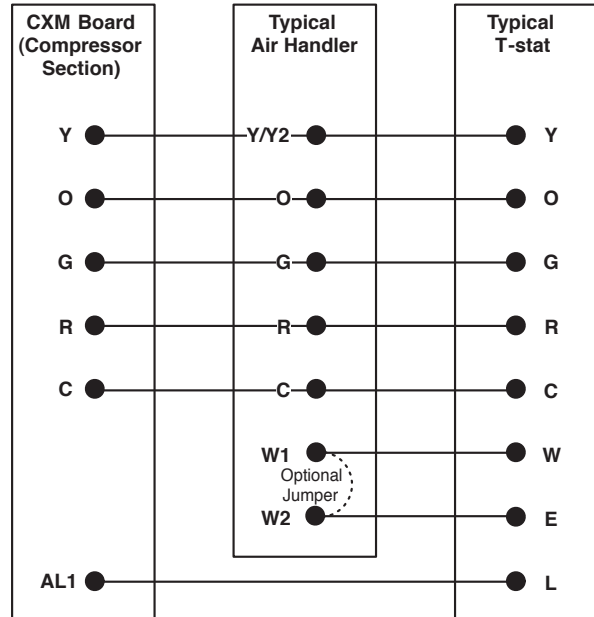
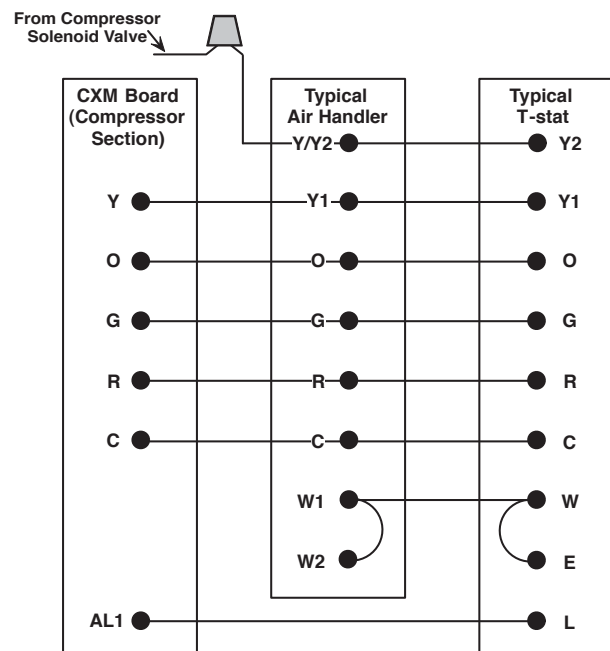

Figure 28b: Typical Thermostat Wiring, Two-Stage Units (3 Heat/2 Cool)



CXM Controls

CXM Control

For detailed control information, see CXM Application, Operation and Maintenance (AOM) manual (part #97B0003N12).

Field Selectable Inputs

Test mode: Test mode allows the service technician to check the operation of the control in a timely manner. By momentarily shorting the test terminals, the CXM control enters a 20 minute test mode period in which all time delays are sped up 15 times. Upon entering test mode, the status LED will flash a code representing the last fault. For diagnostic ease at the thermostat, the alarm relay will also cycle during test mode. The alarm relay will cycle on and off similar to the status LED to indicate a code representing the last fault, at the thermostat. Test mode can be exited by shorting the test terminals for 3 seconds.

Retry Mode: If the control is attempting a retry of a fault, the status LED will slow flash (slow flash = one flash every 2 seconds) to indicate the control is in the process of retrying.

Field Configuration Options

Note: In the following field configuration options, jumper wires should be clipped **ONLY** when power is removed from the CXM control.

Water coil low temperature limit setting: Jumper 3 (JW3-FP1 Low Temp) provides field selection of temperature limit setting for FP1 of 30°F or 10°F [-1°F or -12°C] (refrigerant temperature).

Not Clipped = 30°F [-1°C]. Clipped = 10°F [-12°C].

Air coil low temperature limit setting: Jumper 2 (JW2-FP2 Low Temp) provides field selection of temperature limit setting for FP2 of 30°F or 10°F [-1°F or -12°C] (refrigerant temperature). Note: This jumper should only be clipped under extenuating circumstances, as recommended by the factory.

Not Clipped = 30°F [-1°C]. Clipped = 10°F [-12°C].

Alarm relay setting: Jumper 1 (JW1-AL2 Dry) provides field selection of the alarm relay terminal AL2 to be jumpered to 24VAC or to be a dry contact (no connection).

Not Clipped = AL2 connected to R. Clipped = AL2 dry contact (no connection).

DIP Switches

Note: In the following field configuration options, DIP switches should only be changed when power is removed from the CXM control.

DIP switch 1: Unit Performance Sentinel Disable - provides field selection to disable the UPS feature.

On = Enabled. Off = Disabled.

DIP switch 2: Stage 2 Selection - provides selection of whether compressor has an “on” delay. If set to stage 2, the compressor will have a 3 second delay before energizing. Also, if set for stage 2, the alarm relay will NOT cycle during test mode.

On = Stage 1. Off = Stage 2

DIP switch 3: Not Used.

DIP switch 4: DDC Output at EH2 - provides selection for DDC operation. If set to “DDC Output at EH2,” the EH2 terminal will continuously output the last fault code of the controller. If set to “EH2 normal,” EH2 will operate as standard electric heat output.

On = EH2 Normal. Off = DDC Output at EH2.

NOTE: Some CXM controls only have a 2 position DIP switch package. If this is the case, this option can be selected by clipping the jumper which is in position 4 of SW1.

Jumper not clipped = EH2 Normal. Jumper clipped = DDC Output at EH2.

DIP switch 5: Factory Setting - Normal position is “On.” Do not change selection unless instructed to do so by the factory.

Table 10: CXM LED And Alarm Relay Operations

Description of Operation	LED	Alarm Relay
Normal Mode	On	Open
Normal Mode with UPS Warning	On	Cycle (closed 5 sec., Open 25 sec.)
CXM is non-functional	Off	Open
Fault Retry	Slow Flash	Open
Lockout	Fast Flash	Closed
Over/Under Voltage Shutdown	Slow Flash	Open (Closed after 15 minutes)
Test Mode - No fault in memory	Flashing Code 1	Cycling Code 1
Test Mode - HP Fault in memory	Flashing Code 2	Cycling Code 2
Test Mode - LP Fault in memory	Flashing Code 3	Cycling Code 3
Test Mode - FP1 Fault in memory	Flashing Code 4	Cycling Code 4
Test Mode - FP2 Fault in memory	Flashing Code 5	Cycling Code 5
Test Mode - CO Fault in memory	Flashing Code 6	Cycling Code 6
Test Mode - Over/Under shutdown in memory	Flashing Code 7	Cycling Code 7
Test Mode - UPS in memory	Flashing Code 8	Cycling Code 8
Test Mode - Swapped Thermistor	Flashing Code 9	Cycling Code 9

-Slow Flash = 1 flash every 2 seconds

-Fast Flash = 2 flashes every 1 second

-Flash code 2 = 2 quick flashes, 10 second pause, 2 quick flashes, 10 second pause, etc.

-On pulse 1/3 second; off pulse 1/3 second

CXM Controls

Safety Features – CXM Control

The safety features below are provided to protect the compressor, heat exchangers, wiring and other components from damage caused by operation outside of design conditions.

Anti-short cycle protection: The control features a 5 minute anti-short cycle protection for the compressor.

Note: The 5 minute anti-short cycle also occurs at power up.

Random start: The control features a random start upon power up of 5-80 seconds.

Fault Retry: In Fault Retry mode, the Status LED begins slowly flashing to signal that the control is trying to recover from a fault input. The control will stage off the outputs and then “try again” to satisfy the thermostat input call. Once the thermostat input call is satisfied, the control will continue on as if no fault occurred. If 3 consecutive faults occur without satisfying the thermostat input call, the control will go into “lockout” mode. The last fault causing the lockout will be stored in memory and can be viewed by going into test mode. Note: FP1/FP2 faults are factory set at only one try.

Lockout: In lockout mode, the status LED will begin fast flashing. The compressor relay is turned off immediately. Lockout mode can be “soft” reset by turning off the thermostat (or satisfying the call). A “soft” reset keeps the fault in memory but resets the control. A “hard” reset (disconnecting power to the control) resets the control and erases fault memory.

Lockout with emergency heat: While in lockout mode, if W becomes active (CXM), emergency heat mode will occur.

High pressure switch: When the high pressure switch opens due to high refrigerant pressures, the compressor relay is de-energized immediately since the high pressure switch is in series with the compressor contactor coil. The high pressure fault recognition is immediate (does not delay for 30 continuous seconds before de-energizing the compressor).

High pressure lockout code = 2

Example: 2 quick flashes, 10 sec pause, 2 quick flashes, 10 sec. pause, etc.

Low pressure switch: The low pressure switch must be open and remain open for 30 continuous seconds during “on” cycle to be recognized as a low pressure fault. If the low pressure switch is open for 30 seconds prior to compressor power up it will be considered a low pressure (loss of charge) fault. The low pressure switch input is bypassed for the initial 120 seconds of a compressor run cycle.

Low pressure lockout code = 3

Water coil low temperature (FP1): The FP1 thermistor temperature must be below the selected low temperature limit setting for 30 continuous seconds during a compressor run cycle to be recognized as a FP1 fault. The FP1 input is bypassed for the initial 120 seconds of a compressor run cycle. FP1 is set at the factory for one try. Therefore, the control will go into

lockout mode once the FP1 fault has occurred.

FP1 lockout code = 4

Air coil low temperature (FP2): The FP2 thermistor temperature must be below the selected low temperature limit setting for 30 continuous seconds during a compressor run cycle to be recognized as a FP2 fault. The FP2 input is bypassed for the initial 120 seconds of a compressor run cycle. FP2 is set at the factory for one try. Therefore, the control will go into lockout mode once the FP2 fault has occurred.

FP2 lockout code = 5

Condensate overflow: The condensate overflow sensor must sense overflow level for 30 continuous seconds to be recognized as a CO fault. Condensate overflow will be monitored at all times.

CO lockout code = 6

Over/under voltage shutdown: An over/under voltage condition exists when the control voltage is outside the range of 18VAC to 31.5VAC. Over/under voltage shut down is a self-resetting safety. If the voltage comes back within range for at least 0.5 seconds, normal operation is restored. This is not considered a fault or lockout. If the CXM is in over/under voltage shutdown for 15 minutes, the alarm relay will close.

Over/under voltage shut down code = 7

Unit Performance Sentinel-UPS (patent pending): The UPS feature indicates when the heat pump is operating inefficiently. A UPS condition exists when:

- In heating mode with compressor energized, FP2 is greater than 125°F [52°C] for 30 continuous seconds, or:
- In cooling mode with compressor energized, FP1 is greater than 125°F [52°C] for 30 continuous seconds, or:
- In cooling mode with compressor energized, FP2 is less than 40°F [4.5°C] for 30 continuous seconds. If a UPS condition occurs, the control will immediately go to UPS warning. The status LED will remain on as if the control is in normal mode. Outputs of the control, excluding LED and alarm relay, will NOT be affected by UPS. The UPS condition cannot occur during a compressor off cycle. During UPS warning, the alarm relay will cycle on and off. The cycle rate will be “on” for 5 seconds, “off” for 25 seconds, “on” for 5 seconds, “off” for 25 seconds, etc.

UPS warning code = 8

Swapped FP1/FP2 thermistors: During test mode, the control monitors to see if the FP1 and FP2 thermistors are in the appropriate places. If the control is in test mode, the control will lockout, with code 9, after 30 seconds if:

- The compressor is on in the cooling mode and the FP1 sensor is colder than the FP2 sensor, or:
- The compressor is on in the heating mode and the FP2 sensor is colder than the FP1 sensor.

Swapped FP1/FP2 thermistor code = 9.

Diagnostic Features

The LED on the CXM board advises the technician of the current status of the CXM control. The LED can display either the current CXM mode or the last fault in memory if in test mode. If there is no fault in memory, the LED will flash Code 1 (when in test mode).

CXM Controls

CXM Control Start-up Operation

The control will not operate until all inputs and safety controls are checked for normal conditions. The compressor will have a 5 minute anti-short cycle delay at power-up. The first time after power-up that there is a call for compressor, the compressor will follow a 5 to 80 second random start delay. After the random start delay and anti-short cycle delay, the compressor relay will be energized. On all subsequent compressor calls, the random start delay is omitted.

Table 11: Unit Operation

T-stat signal	TTS
	Variable Speed Air Handler
G	Fan only
G, Y or Y1	Stage 1 heating ¹
G, Y1, Y2	Stage 2 heating ¹
G, Y1, Y2, W	Stage 3 heating ¹
G, W	Emergency heat
G, Y or Y1, O	Stage 1 cooling ²
G, Y1, Y2, O	Stage 2 cooling ²

- Stage 1 = 1st stage compressor, 1st stage fan operation
 Stage 2 = 2nd stage compressor, 2nd stage fan operation
 Stage 3 = 2nd stage compressor, auxiliary electric heat, 2nd or 3rd stage fan operation (depending on fan settings)
- Stage 1 = 1st stage compressor, 1st stage fan operation, reversing valve
 Stage 2 = 2nd stage compressor, 2nd stage fan operation, reversing valve

CXM Thermostat Details

Thermostat Compatibility - Most all heat pump thermostats can be used with the CXM control. **However Heat/Cool stats are NOT compatible with the CXM.**

Anticipation Leakage Current - Maximum leakage current for "Y" is 50 mA and for "W" is 20mA. Triacs can be used if leakage current is less than above. Thermostats with anticipators can be used if anticipation current is less than that specified above.

Thermostat Signals -

- "Y" and "W" have a 1 second recognition time when being activated or being removed.
- "O" and "G" are direct pass through signals but are monitored by the micro processor.
- "R" and "C" are from the transformer.
- "AL1" and "AL2" originate from the alarm relay.
- "A" is paralleled with the compressor output for use with well water solenoid valves.
- The "Y" 1/4" quick connect is a connection point to the "Y" input terminal P1 for factory use. This "Y" terminal can be used to drive panel mounted relays such as the loop pump relay.

Table 12: Nominal resistance at various temperatures

Temp (°C)	Temp (°F)	Resistance (kOhm)	Temp (°C)	Temp (°F)	Resistance (kOhm)
-17.8	0.0	85.41	55	131.0	2.99
-17.5	0.5	84.16	56	132.8	2.88
-16.9	1.5	81.43	57	134.6	2.77
-12	10.4	61.70	58	136.4	2.67
-11	12.2	58.40	59	138.2	2.58
-10	14.0	55.30	60	140.0	2.49
-9	15.8	52.40	61	141.8	2.40
-8	17.6	49.60	62	143.6	2.32
-7	19.4	47.00	63	145.4	2.23
-6	21.2	44.60	64	147.2	2.16
-5	23.0	42.30	65	149.0	2.08
-4	24.8	40.10	66	150.8	2.01
-3	26.6	38.10	67	152.6	1.94
-2	28.4	36.10	68	154.4	1.88
-1	30.2	34.30	69	156.2	1.81
0	32.0	32.60	70	158.0	1.75
1	33.8	31.00	71	159.8	1.69
2	35.6	29.40	72	161.6	1.64
3	37.4	28.00	73	163.4	1.58
4	39.2	26.60	74	165.2	1.53
5	41.0	25.30	75	167.0	1.48
6	42.8	24.10	76	168.8	1.43
7	44.6	23.00	77	170.6	1.38
8	46.4	21.90	78	172.4	1.34
9	48.2	20.80	79	174.2	1.30
10	50.0	19.90	80	176.0	1.26
11	51.8	18.97	81	177.8	1.22
12	53.6	18.09	82	179.6	1.18
13	55.4	17.25	83	181.4	1.14
14	57.2	16.46	84	183.2	1.10
15	59.0	15.71	85	185.0	1.07
16	60.8	15.00	86	186.8	1.04
17	62.6	14.32	87	188.6	1.00
18	64.4	13.68	88	190.4	0.97
19	66.2	13.07	89	192.2	0.94
20	68.0	12.49	90	194.0	0.92
21	69.8	11.94	91	195.8	0.89
22	71.6	11.42	92	197.6	0.86
23	73.4	10.92	93	199.4	0.84
24	75.2	10.45	94	201.2	0.81
25	77.0	10.00	95	203.0	0.79
26	78.8	9.57	96	204.8	0.76
27	80.6	9.17	97	206.6	0.74
28	82.4	8.78	98	208.4	0.72
29	84.2	8.41	99	210.2	0.70
30	86.0	8.06	100	212.0	0.68
31	87.8	7.72	101	213.8	0.66
32	89.6	7.40	102	215.6	0.64
33	91.4	7.10	103	217.4	0.62
34	93.2	6.81	104	219.2	0.60
35	95.0	6.53	105	221.0	0.59
36	96.8	6.27	106	222.8	0.57
37	98.6	6.02	107	224.6	0.56
38	100.4	5.78	108	226.4	0.54
39	102.2	5.55	109	228.2	0.53
40	104.0	5.33	110	230.0	0.51
41	105.8	5.12	111	231.8	0.50
42	107.6	4.92	112	233.6	0.48
43	109.4	4.73	113	235.4	0.47
44	111.2	4.54	114	237.2	0.46
45	113.0	4.37	115	239.0	0.45
46	114.8	4.20	116	240.8	0.43
47	116.6	4.04	117	242.6	0.42
48	118.4	3.89	118	244.4	0.41
49	120.2	3.74	119	246.2	0.40
50	122.0	3.60	120	248.0	0.39
51	123.8	3.47	121	249.8	0.38
52	125.6	3.34	122	251.6	0.37
53	127.4	3.22	123	253.4	0.36
54	129.2	3.10			

Rev.: 5/23/00 m

Unit Starting and Operating Conditions

Operating Limits

Environment – Units are designed for indoor installation only. Never install in areas subject to freezing or where humidity levels could cause cabinet condensation (such as unconditioned spaces subject to 100% outside air). Power Supply – A voltage variation of +/- 10% of nameplate utilization voltage is acceptable.

Determination of operating limits is dependent primarily upon three factors: 1) return air temperature. 2) water temperature, and 3) ambient temperature. When any one of these factors is at minimum or maximum levels, the other two factors should be at normal levels to insure proper unit operation. Extreme variations in temperature and humidity and/or corrosive water or air will adversely affect unit performance, reliability, and service life. Consult Table 13a for operating limits.

Table 13a: Building Operating Limits

Operating Limits	TTS		Operating Limits	TTP	
	Cooling	Heating		Cooling	Heating
Air Limits			Air Limits		
Min. ambient air, DB	45°F [7°C]	39°F [4°C]	Min. ambient air, DB	-10°F [-23°C]	-10°F [-23°C]
Rated ambient air, DB	80.6°F [27°C]	68°F [20°C]	Rated ambient air, DB	80.6°F [27°C]	68°F [20°C]
Max. ambient air, DB	110°F [43°C]	85°F [29°C]	Max. ambient air, DB	110°F [43°C]	85°F [29°C]
Min. entering air, DB/WB	60/45°F [16/7°C]	40°F [4.4°C]	Min. entering air, DB/WB	60/45°F [16/7°C]	40°F [4.4°C]
Rated entering air, DB/WB	80.6/66.2°F [27/19°C]	68°F [20°C]	Rated entering air, DB/WB	80.6/66.2°F [27/19°C]	68°F [20°C]
Max. entering air, DB/WB	100/75°F [38/24°C]	80°F [27°C]	Max. entering air, DB/WB	100/75°F [38/24°C]	80°F [27°C]
Water Limits			Water Limits		
Min. entering water	30°F [-1°C]	20°F [-6.7°C]	Min. entering water	30°F [-1°C]	20°F [-6.7°C]
Normal entering water	50-110°F [10-43°C]	30-70°F [-1 to 21°C]	Normal entering water	50-110°F [10-43°C]	30-70°F [-1 to 21°C]
Max. entering water	120°F [49°C]	90°F [32°C]	Max. entering water	120°F [49°C]	90°F [32°C]
Normal Water Flow	1.5 to 3.0 gpm / ton [1.6 to 3.2 l/m per kW]		Normal Water Flow	1.5 to 3.0 gpm / ton [1.6 to 3.2 l/m per kW]	

Rev.: 9 June, 2009P

Created: 23 June, 2009B

Commissioning Limits

Consult Table 13b for the particular model. Starting conditions vary depending upon model and are based upon the following notes:

Notes:

- Commissioning limits in Table 13b are not normal or continuous operating conditions. Minimum/maximum limits are start-up conditions to bring the building space up to occupancy temperatures. Units are not designed to operate under these conditions on a regular basis.
- Voltage utilization range complies with AHRI Standard 110.

Table 13b: Building Commissioning Limits

Commissioning Limits	TTS		Commissioning Limits	TTP	
	Cooling	Heating		Cooling	Heating
Air Limits			Air Limits		
Min. ambient air, DB	45°F [7°C]	39°F [4°C]	Min. ambient air, DB	-10°F [-23°C]	-10°F [-23°C]
Rated ambient air, DB	80.6°F [27°C]	68°F [20°C]	Rated ambient air, DB	80.6°F [27°C]	68°F [20°C]
Max. ambient air, DB	110°F [43°C]	85°F [29°C]	Max. ambient air, DB	110°F [43°C]	85°F [29°C]
Min. entering air, DB/WB	50°F [10°C]	40°F [4.5°C]	Min. entering air, DB/WB	50°F [10°C]	40°F [4.5°C]
Rated entering air, DB/WB	80.6/66.2°F [27/19°C]	68°F [20°C]	Rated entering air, DB/WB	80.6/66.2°F [27/19°C]	68°F [20°C]
Max. entering air, DB/WB	110/83°F [43/28°C]	80°F [27°C]	Max. entering air, DB/WB	110/83°F [43/28°C]	80°F [27°C]
Water Limits			Water Limits		
Min. entering water	30°F [-1°C]	20°F [-6.7°C]	Min. entering water	30°F [-1°C]	20°F [-6.7°C]
Normal entering water	50-110°F [10-43°C]	30-70°F [-1 to 21°C]	Normal entering water	50-110°F [10-43°C]	30-70°F [-1 to 21°C]
Max. entering water	120°F [49°C]	90°F [32°C]	Max. entering water	120°F [49°C]	90°F [32°C]
Normal Water Flow	1.5 to 3.0 gpm / ton [1.6 to 3.2 l/m per kW]		Normal Water Flow	1.5 to 3.0 gpm / ton [1.6 to 3.2 l/m per kW]	

Rev.: 9 June, 2009P

Created: 23 June, 2009B

Unit Starting and Operating Conditions

Unit and System Checkout

BEFORE POWERING SYSTEM, please check the following:

UNIT CHECKOUT

- Balancing/shutoff valves: Insure that all isolation valves are open and water control valves are wired.
- Line voltage and wiring: Verify that voltage is within an acceptable range for the unit and wiring and fuses/breakers are properly sized. Verify that low voltage wiring is complete.
- Unit control transformer: Insure that transformer has the properly selected voltage tap. Residential 208-230V units are factory wired for 230V operation unless specified otherwise.
- Loop/water piping is complete and purged of air. Water/piping is clean.
- Antifreeze has been added if necessary.
- Entering water and air: Insure that entering water and air temperatures are within operating limits of Table 13b.
- Low water temperature cutout: Verify that low water temperature cut-out on the CXM/DXM control is properly set.
- Unit fan: Manually rotate fan to verify free rotation and insure that blower wheel is secured to the motor shaft. Be sure to remove any shipping supports if needed. DO NOT oil motors upon start-up. Fan motors are pre-oiled at the factory. Check unit fan speed selection and compare to design requirements.
- Condensate line: Verify that condensate line is open and properly pitched toward drain.
- HWG pump is disconnected unless piping is completed and air has been purged from the system.
- Water flow balancing: Record inlet and outlet water temperatures for each heat pump upon startup. This check can eliminate nuisance trip outs and high velocity water flow that could erode heat exchangers.
- Unit air coil and filters: Insure that filter is clean and accessible. Clean air coil of all manufacturing oils.
- Unit controls: Verify that CXM field selection options are properly set. Low voltage wiring is complete.
- Blower speed is set.
- Service/access panels are in place.

⚠ CAUTION! ⚠

CAUTION! To avoid equipment damage, DO NOT allow system water pressure to exceed 100 psi. when using the TTP Outdoor Compressor Section. The expansion tank in the TTP has a maximum working water pressure of 100 psi. Any pressure in excess of 100 psi may damage the expansion tank.

SYSTEM CHECKOUT

- System water temperature: Check water temperature for proper range and also verify heating and cooling set points for proper operation.
- System pH: Check and adjust water pH if necessary to

maintain a level between 6 and 8.5. Proper pH promotes longevity of hoses and fittings (see Table 4).

- System flushing: Verify that all air is purged from the system. Air in the system can cause poor operation or system corrosion. Water used in the system must be potable quality initially and clean of dirt, piping slag, and strong chemical cleaning agents. Some antifreeze solutions may require distilled water.
- Flow Controller pump(s): Verify that the pump(s) is wired, purged of air, and in operating condition.
- System controls: Verify that system controls function and operate in the proper sequence.
- Low water temperature cutout: Verify that low water temperature cut-out controls are set properly (FP1 - JW3).
- Miscellaneous: Note any questionable aspects of the installation.

⚠ CAUTION! ⚠

CAUTION! Verify that ALL water control valves are open and allow water flow prior to engaging the compressor. Freezing of the coax or water lines can permanently damage the heat pump.

NOTICE! Failure to remove shipping brackets from spring-mounted compressors will cause excessive noise, and could cause component failure due to added vibration.

⚠ CAUTION! ⚠

CAUTION! To avoid equipment damage, DO NOT leave system filled in a building without heat during the winter unless antifreeze is added to the water loop. Heat exchangers never fully drain by themselves and will freeze unless winterized with antifreeze.

Unit Start-up Procedure

1. Always deactivate the HWG (on units equipped with an HWG) before completing the following steps.
2. Turn the thermostat fan position to "ON." Blower should start.
3. Balance air flow at registers.
4. Adjust all valves to their full open position. Turn on the line power to all heat pump units.
5. Room temperature should be within the minimum-maximum ranges of Table 13b. During start-up checks, loop water temperature entering the heat pump should be between 30°F [-1°C] and 95°F [35°C].
6. Two factors determine the operating limits of water source heat pumps, (a) return air temperature, and (b) water temperature. When any one of these factors is at a minimum or maximum level, the other factor must be at normal level to insure proper unit operation.
 - a. Adjust the unit thermostat to the warmest setting. Place the thermostat mode switch in the "COOL"

Unit Start-Up Procedure

- position. Slowly reduce thermostat setting until the compressor activates.
- b. Check for cool air delivery at the unit grille within a few minutes after the unit has begun to operate. Note: Units have a five minute time delay in the control circuit that can be bypassed on the CXM/DXM control board as shown below in Figure 20. See controls description for details.
- c. Verify that the compressor is on and that the water flow rate is correct by measuring pressure drop through the heat exchanger using the P/T plugs and comparing to Table 14.
- d. Check the elevation and cleanliness of the condensate lines. Dripping may be a sign of a blocked line. Check that the condensate trap is filled to provide a water seal.
- e. Refer to Table 15. Check the temperature of both entering and leaving water. If temperature is within range, proceed with the test. If temperature is outside of the operating range, check refrigerant pressures and compare to Tables 16a through 16d. Verify correct water flow by comparing unit pressure drop across the heat exchanger versus the data in Table 14. Heat of rejection (HR) can be calculated and compared to catalog data capacity pages. The formula for HR for systems with water is as follows: $HR = TD \times GPM \times 500$, where TD is the temperature difference between the entering and leaving water, and GPM is the flow rate in U.S. GPM, determined by comparing the pressure drop across the heat exchanger to Table 14.
- f. Check air temperature drop across the air coil when compressor is operating. Air temperature drop should be between 15°F and 25°F [8°C and 14°C].
- g. Turn thermostat to "OFF" position. A hissing noise indicates proper functioning of the reversing valve.
7. Allow five (5) minutes between tests for pressure to equalize before beginning heating test.
 - a. Adjust the thermostat to the lowest setting. Place the thermostat mode switch in the "HEAT" position.
 - b. Slowly raise the thermostat to a higher temperature until the compressor activates.
 - c. Check for warm air delivery within a few minutes after the unit has begun to operate.
 - d. Refer to Table 15. Check the temperature of both entering and leaving water. If temperature is within range, proceed with the test. If temperature is outside of the operating range, check refrigerant pressures and compare to Tables 16a through 16d. Verify correct water flow by comparing unit pressure drop across the heat exchanger versus the data in Table 14. Heat of extraction (HE) can be calculated and compared to submittal data capacity pages. The formula for HE for systems with water is as follows: $HE = TD \times GPM \times 500$, where TD is the temperature difference between the entering and leaving water, and GPM is the flow rate in U.S. GPM, determined by comparing the pressure drop across the heat exchanger to Table 14.

- e. Check air temperature rise across the air coil when compressor is operating. Air temperature rise should be between 20°F and 30°F [11°C and 17°C].
- f. Check for vibration, noise, and water leaks.
8. If unit fails to operate, perform troubleshooting analysis (see troubleshooting section). If the check described fails to reveal the problem and the unit still does not operate, contact a trained service technician to insure proper diagnosis and repair of the equipment.
9. When testing is complete, set system to maintain desired comfort level.
10. BE CERTAIN TO FILL OUT AND RETURN ALL WARRANTY REGISTRATION PAPERWORK.

Note: If performance during any mode appears abnormal, refer to the CXM section or troubleshooting section of this manual. To obtain maximum performance, the air coil should be cleaned before start-up. A 10% solution of dishwasher detergent and water is recommended.

⚠ WARNING! ⚠

WARNING! When the disconnect switch is closed, high voltage is present in some areas of the electrical panel. Exercise caution when working with energized equipment.

⚠ CAUTION! ⚠

CAUTION! Verify that ALL water control valves are open and allow water flow prior to engaging the compressor. Freezing of the coax or water lines can permanently damage the heat pump.

Figure 29: Test Mode Pins

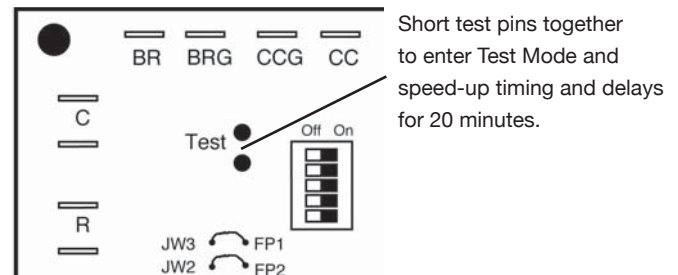

Unit Operating Conditions

Table 14: Two-Stage R-410A Compressor Section Coax Water Pressure Drop

Model	GPM	Pressure Drop (psi)			
		30°F	50°F	70°F	90°F
026	4.0	1.5	1.3	1.1	1.0
	6.0	3.1	2.6	2.3	2.1
	7.0	4.1	3.4	3.0	2.7
	8.0	5.1	4.3	3.8	3.4
038	4.0	1.2	1.0	0.8	0.6
	6.0	2.6	2.5	2.3	2.1
	8.0	4.5	4.2	4.0	3.7
	9.0	5.7	5.2	4.8	4.4
049	5.5	1.1	0.9	0.8	0.7
	8.3	2.2	2.1	2.0	1.8
	11.0	3.9	3.6	3.2	3.1
	12.0	4.5	4.2	3.8	3.5
064	7.0	0.5	0.3	0.2	0.1
	10.5	1.9	1.8	1.7	1.6
	14.0	3.9	3.5	3.2	2.9
	15.0	4.8	4.3	3.9	3.5

Table 15: Water Temperature Change Through Heat Exchanger

Water Flow, gpm (l/m)	Rise, Cooling °F (°C)	Drop, Heating °F (°C)
For Closed Loop: Ground Source or Closed Loop Systems at 3 gpm per ton (3.9 l/m per kw)	9 - 12 (5 - 6.7)	4 - 8 (2.2 - 4.4)
For Open Loop: Ground Water Systems at 1.5 gpm per ton (2.0 l/m per kw)	20 - 26 (11.1 - 14.4)	10 - 17 (5.6 - 9.4)

Table 16a: Size 026 Two-Stage R-410A Typical Unit Operating Pressures and Temperatures

Entering Water Temp °F	Water Flow GPM/ton	Full Load Cooling - without HWG active						Full Load Heating - without HWG active					
		Suction Pressure PSIG	Discharge Pressure PSIG	Super-heat	Sub-cooling	Water Temp Rise °F	Air Temp Drop °F DB	Suction Pressure PSIG	Discharge Pressure PSIG	Super-heat	Sub-cooling	Water Temp Drop °F	Air Temp Rise °F DB
30*	1.5	122-132	159-179	13-18	9-14	16.7-18.7	18-24	77-87	278-298	4-9	10-15	5.9-7.9	18-24
	2.25	122-132	146-166	13-18	7-12	12.3-14.3	19-25	79-89	280-300	4-9	10-15	4.2-6.2	19-25
	3	122-132	132-152	14-19	7-12	7.9-9.9	19-25	82-92	282-302	4-9	10-15	2.7-4.7	20-26
50	1.5	132-142	186-206	8-13	8-13	16.3-18.3	18-24	107-117	314-334	6-11	13-18	8.9-10.9	25-31
	2.25	132-142	172-192	8-13	6-11	12.1-14.1	19-25	111-121	315-335	6-11	13-18	6.7-8.7	26-32
	3	132-142	158-178	8-13	6-11	7.8-9.8	19-25	115-125	317-337	6-11	13-18	4.5-6.5	26-32
70	1.5	139-149	281-301	7-12	8-13	15.7-17.7	18-24	139-149	350-370	7-12	15-20	11.3-13.3	31-38
	2.25	139-149	267-287	7-12	8-13	11.6-13.6	18-24	145-155	352-372	7-12	15-20	8.5-10.5	32-39
	3	139-149	253-273	7-12	7-12	7.6-9.6	18-24	152-162	354-374	7-12	15-20	5.8-7.8	32-39
90	1.5	141-151	374-394	7-12	9-14	14.6-16.6	17-23	177-187	392-412	9-14	17-22	14.4-16.4	37-45
	2.25	141-151	360-380	7-12	9-14	10.7-12.7	17-23	181-191	397-417	10-15	17-22	10.8-12.8	38-46
	3	141-151	346-366	7-12	8-13	6.9-8.9	17-23	186-196	402-422	11-16	17-22	7.1-9.1	38-46
110	1.5	145-155	473-493	7-12	10-15	13.6-15.6	16-22	Operation Not Recommended					
	2.25	145-155	458-478	7-12	10-15	9.9-11.9	16-22						
	3	145-155	441-461	7-12	9-14	6.2-8.2	16-22						

*Based on 15% methanol antifreeze solution

Table 16b: Size 038 Two-Stage R-410A Typical Unit Operating Pressures and Temperatures

Entering Water Temp °F	Water Flow GPM/ton	Full Load Cooling - without HWG active						Full Load Heating - without HWG active					
		Suction Pressure PSIG	Discharge Pressure PSIG	Super-heat	Sub-cooling	Water Temp Rise °F	Air Temp Drop °F DB	Suction Pressure PSIG	Discharge Pressure PSIG	Super-heat	Sub-cooling	Water Temp Drop °F	Air Temp Rise °F DB
30*	1.5	122-132	153-173	18-23	9-14	22.1-24.1	19-25	71-81	263-283	5-10	2-5	8.1-10.1	17-23
	2.25	121-131	145-165	18-23	8-13	16.8-18.8	20-26	75-85	267-287	5-10	2-5	5.9-7.9	18-24
	3	121-131	135-155	18-23	8-13	10.5-12.5	20-26	78-88	270-290	5-10	2-5	3.7-5.7	19-25
50	1.5	131-141	222-242	13-18	10-15	21.9-23.9	19-25	103-113	292-312	6-11	2.5-7	11.5-13.5	23-29
	2.25	130-140	208-228	13-18	9-14	16.1-18.1	20-26	107-117	296-316	6-11	2.5-7	8.6-10.6	24-30
	3	130-140	194-214	14-19	9-14	10.3-12.3	20-26	112-122	301-321	6-11	2.5-7	5.7-7.7	24-30
70	1.5	138-148	299-319	8-13	13-18	21.5-23.5	19-25	134-144	322-342	7-12	2.5-7	14.5-16.5	28-35
	2.25	137-147	280-300	8-13	12-17	15.8-17.8	20-26	140-150	328-358	7-12	2.5-7	11.1-13.1	29-36
	3	137-147	263-283	8-13	12-17	10-12	20-26	146-156	334-354	7-12	2.5-7	7.7-9.7	30-37
90	1.5	142-152	388-408	6-11	13-18	20.5-22.5	18-24	172-182	360-380	8-13	2.5-7	20.5-22.5	36-44
	2.25	142-152	367-387	7-12	8-13	14.9-16.9	18-24	184-194	369-389	8-13	2.5-7	15-17	37-45
	3	142-152	347-367	7-12	8-13	9.3-11.3	18-24	196-206	378-398	8-13	2.5-7	10-12	39-47
110	1.5	147-157	486-506	6-11	13-18	19-21	18-24	Operation Not Recommended					
	2.25	147-157	465-475	7-12	8-13	14-16	18-24						
	3	147-157	444-464	7-12	8-13	9-11	18-24						

*Based on 15% methanol antifreeze solution

Unit Operating Conditions

Table 16c: Size 049 Two-Stage R-410A Typical Unit Operating Pressures and Temperatures

Entering Water Temp °F	Water Flow GPM/ton	Full Load Cooling - without HWG active						Full Load Heating - without HWG active					
		Suction Pressure PSIG	Discharge Pressure PSIG	Super-heat	Sub-cooling	Water Temp Rise °F	Air Temp Drop °F DB	Suction Pressure PSIG	Discharge Pressure PSIG	Super-heat	Sub-cooling	Water Temp Drop °F	Air Temp Rise °F DB
30*	1.5	112-122	187-207	18-23	23-28	20.7-22.7	19-25	66-76	261-281	8-13	5-10	8-10	18-24
	2.25	111-121	167-187	18-23	21-26	15.5-17.5	19-25	69-79	264-284	8-13	5-10	6-8	19-25
	3	111-121	147-167	18-23	20-25	10.2-12.2	19-25	72-82	267-287	8-13	5-10	4-6	19-25
50	1.5	125-135	245-265	13-18	19-24	20.9-22.9	20-26	93-103	289-309	7-12	5-10	11.5-13.5	23-29
	2.25	123-133	227-247	13-18	18-23	15.6-17.6	20-26	98-108	295-315	7-12	5-10	8.7-10.7	24-30
	3	122-132	208-228	14-19	16-21	10.2-12.2	20-26	103-113	301-321	7-12	5-10	5.9-7.9	25-31
70	1.5	133-143	314-334	9-14	17-22	20.5-22.5	20-26	123-133	319-339	7-12	5-10	15-17	28-35
	2.25	132-142	294-314	9-14	16-21	15.2-17.2	20-26	130-140	329-349	7-12	5-10	11.5-13.5	29-36
	3	131-141	274-294	10-15	14-19	9.9-11.9	20-26	137-147	336-356	7-12	5-10	7.9-9.9	30-37
90	1.5	138-148	401-421	8-13	16-21	19.2-21.2	19-25	167-177	365-385	7-12	5-10	19.6-21.6	37-45
	2.25	137-147	379-399	8-13	15-20	14.3-16.3	19-25	177-187	374-394	7-12	5-10	15-17	38-46
	3	136-146	357-377	9-14	13-18	9.3-11.3	19-25	187-197	388-408	7-12	5-10	10.3-12.3	39-47
110	1.5	144-154	502-522	8-13	14-19	18-20	18-24	Operation Not Recommended					
	2.25	143-153	477-497	8-13	13-18	13.3-15.3	18-24						
	3	142-152	452-472	9-14	12-17	8.5-10.5	18-24						

*Based on 15% methanol antifreeze solution

Table 16d: Size 064 Two-Stage R-410A Typical Unit Operating Pressures and Temperatures

Entering Water Temp °F	Water Flow GPM/ton	Full Load Cooling - without HWG active						Full Load Heating - without HWG active					
		Suction Pressure PSIG	Discharge Pressure PSIG	Super-heat	Sub-cooling	Water Temp Rise °F	Air Temp Drop °F DB	Suction Pressure PSIG	Discharge Pressure PSIG	Super-heat	Sub-cooling	Water Temp Drop °F	Air Temp Rise °F DB
30*	1.5	117-127	160-180	16-21	8-13	17.5-19.5	16-22	66-76	282-302	9-15	8-13	8-10	21-27
	2.25	116-126	133-153	17-22	6-11	11.9-13.9	16-22	69-79	285-305	9-15	8-13	6-8	21-27
	3	115-125	125-145	18-23	5-10	6.3-8.3	16-22	72-82	289-309	9-15	9-14	4-6	22-28
50	1.5	126-136	228-248	8-13	8-13	19.8-21.8	20-26	95-105	318-338	9-15	12-17	11.3-13.3	27-33
	2.25	124-134	212-232	11-16	6-11	14.2-16.2	20-26	100-110	321-341	9-15	12-17	8.5-10.5	28-34
	3	123-133	195-215	14-19	5-10	8.5-10.5	20-26	105-115	324-344	9-15	12-17	5.7-7.7	30-36
70	1.5	130-140	305-325	8-13	10-15	20.3-22.3	21-27	128-138	360-380	8-14	12-17	14-16	33-38
	2.25	129-139	286-306	9-14	9-14	14.8-16.8	21-27	133-143	364-384	8-14	12-17	10.6-12.6	34-40
	3	128-138	266-286	11-16	7-12	9.3-11.3	21-27	139-149	368-388	8-14	12-17	7.3-9.3	35-41
90	1.5	133-143	398-418	8-13	10-15	19.4-21.4	20-26	173-183	407-427	8-14	13-18	18.2-20.2	42-50
	2.25	132-142	376-396	8-13	9-14	14.1-16.1	20-26	177-187	411-431	8-14	13-18	13.9-15.9	43-51
	3	132-142	354-374	8-13	7-12	8.8-10.8	20-26	182-192	415-435	8-14	14-19	9.6-11.6	44-52
110	1.5	138-148	505-525	6-11	10-15	18.3-20.3	19-25	Operation Not Recommended					
	2.25	137-147	483-503	6-11	9-14	13.3-15.3	19-25						
	3	136-146	459-479	6-11	8-13	8.3-10.3	19-25						

*Based on 15% methanol antifreeze solution

Preventive Maintenance

Water Coil Maintenance

(Direct ground water applications only)

If the system is installed in an area with a known high mineral content (125 P.P.M. or greater) in the water, it is best to establish a periodic maintenance schedule with the owner so the coil can be checked regularly. Consult the well water applications section of this manual for a more detailed water coil material selection. Should periodic coil cleaning be necessary, use standard coil cleaning procedures, which are compatible with the heat exchanger material and copper water lines. Generally, the more water flowing through the unit, the less chance for scaling. Therefore, 1.5 gpm per ton [2.0 l/m per kW] is recommended as a minimum flow. Minimum flow rate for entering water temperatures below 50°F [10°C] is 2.0 gpm per ton [2.6 l/m per kW].

Water Coil Maintenance

(All other water loop applications)

Generally water coil maintenance is not needed for closed loop systems. However, if the piping is known to have high dirt or debris content, it is best to establish a periodic maintenance schedule with the owner so the water coil can be checked regularly. Dirty installations are typically the result of deterioration of iron or galvanized piping or components in the system. Open cooling towers requiring heavy chemical treatment and mineral buildup through water use can also contribute to higher maintenance. Should periodic coil cleaning be necessary, use standard coil cleaning procedures, which are compatible with both the heat exchanger material and copper water lines. Generally, the more water flowing through the unit, the less chance for scaling. However, flow rates over 3 gpm per ton (3.9 l/m per kW) can produce water (or debris) velocities that can erode the heat exchanger wall and ultimately produce leaks.

Hot Water Generator Coils

See water coil maintenance for ground water units. If the potable water is hard or not chemically softened, the high temperatures of the desuperheater will tend to scale even quicker than the water coil and may need more frequent inspections. In areas with extremely hard water, a HWG is not recommended.

Filters

Filters must be clean to obtain maximum performance. Filters should be inspected every month under normal operating conditions and be replaced when necessary. Units should never be operated without a filter.

Washable, high efficiency, electrostatic filters, when dirty, can exhibit a very high pressure drop for the fan motor and reduce air flow, resulting in poor performance. It is especially important to provide consistent washing of these filters (in the opposite direction of the normal air flow) once per month using a high pressure wash similar to those found at self-serve car washes.

Condensate Drain

In areas where airborne bacteria may produce a “slimy” substance in the drain pan, it may be necessary to treat the drain pan chemically with an algaecide approximately every three months to minimize the problem. The condensate pan may also need to be cleaned periodically to insure indoor air quality. The condensate drain can pick up lint and dirt, especially with dirty filters. Inspect the drain twice a year to avoid the possibility of plugging and eventual overflow.

Compressor

Conduct annual amperage checks to insure that amp draw is no more than 10% greater than indicated on the serial plate data.

Fan Motors

Consult air handler I.O.M. for maintenance requirements.

Air Coil

The air coil must be cleaned to obtain maximum performance. Check once a year under normal operating conditions and, if dirty, brush or vacuum clean. Care must be taken not to damage the aluminum fins while cleaning. CAUTION: Fin edges are sharp.

Cabinet - “Indoor” Compressor Section

Do not allow water to stay in contact with the cabinet for long periods of time to prevent corrosion of the cabinet sheet metal. Generally, cabinets are set up from the floor a few inches [7 - 8 cm] to prevent water from entering the cabinet. The cabinet can be cleaned using a mild detergent.

Refrigerant System

To maintain sealed circuit integrity, do not install service gauges unless unit operation appears abnormal. Reference the operating charts for pressures and temperatures. Verify that air and water flow rates are at proper levels before servicing the refrigerant circuit.

Troubleshooting

General

If operational difficulties are encountered, perform the preliminary checks below before referring to the troubleshooting charts.

- Verify that the unit is receiving electrical supply power.
- Make sure the fuses in the fused disconnect switches are intact.

After completing the preliminary checks described above, inspect for other obvious problems such as leaking connections, broken or disconnected wires, etc. If everything appears to be in order, but the unit still fails to operate properly, refer to the “CXM Troubleshooting Process Flowchart” or “Functional Troubleshooting Chart.”

CXM Board

CXM board troubleshooting in general is best summarized as simply verifying inputs and outputs. After inputs and outputs have been verified, board operation is confirmed and the problem must be elsewhere. Below are some general guidelines for troubleshooting the CXM control.

Field Inputs

All inputs are 24VAC from the thermostat and can be verified using a volt meter between C and Y, G, O, W. 24VAC will be present at the terminal (for example, between “Y” and “C”) if the thermostat is sending an input to the CXM board.

Sensor Inputs

All sensor inputs are ‘paired wires’ connecting each component to the board. Therefore, continuity on pressure switches, for example can be checked at the board connector.

The thermistor resistance should be measured with the connector removed so that only the impedance of the thermistor is measured. If desired, this reading can be compared to the thermistor resistance chart shown in the CXM AOM manual. An ice bath can be used to check calibration of the thermistor.

Outputs

The compressor relay is 24VAC and can be verified using a voltmeter. The fan signal is passed through the board to the external fan relay (units with PSC motors only). The alarm relay can either be 24VAC as shipped or dry contacts for use with DDC controls by clipping the JW1 jumper. Electric heat outputs are 24VDC “ground sinking” and require a volt meter set for DC to verify operation. The terminal marked “24VDC” is the 24VDC supply to the electric heat board; terminal “EH1” is stage 1 electric heat; terminal “EH2” is stage 2 electric heat. When electric heat is energized (thermostat is sending a “W” input to the CXM controller), there will be 24VDC between terminal “24VDC” and “EH1” (stage 1 electric heat) and/or “EH2” (stage 2 electric heat). A reading of 0VDC between “24VDC” and “EH1” or “EH2” will indicate that the CXM board is NOT sending an output signal to the electric heat board.

Test Mode

Test mode can be entered for 20 minutes by shorting the test pins (see Figure 29). The CXM board will automatically exit test mode after 20 minutes.

CXM Troubleshooting Process Flowchart/Functional Troubleshooting Chart

The “CXM Troubleshooting Process Flowchart” is a quick overview of how to start diagnosing a suspected problem, using the fault recognition features of the CXM board. The “Functional Troubleshooting Chart” on the following page is a more comprehensive method for identifying a number of malfunctions that may occur, and is not limited to just the CXM controls. Within the chart are five columns:

- The “Fault” column describes the symptoms.
- Columns 2 and 3 identify in which mode the fault is likely to occur, heating or cooling.
- The “Possible Cause” column identifies the most likely sources of the problem.
- The “Solution” column describes what should be done to correct the problem.

⚠ WARNING! ⚠

WARNING! HAZARDOUS VOLTAGE! DISCONNECT ALL ELECTRIC POWER INCLUDING REMOTE DISCONNECTS BEFORE SERVICING.

Failure to disconnect power before servicing can cause severe personal injury or death.

CXM Process Flow Chart

⚠ WARNING! ⚠

WARNING! HAZARDOUS VOLTAGE! DISCONNECT ALL ELECTRIC POWER INCLUDING REMOTE DISCONNECTS BEFORE SERVICING. Failure to disconnect power before servicing can cause severe personal injury or death.

CXM Functional Troubleshooting Flow Chart

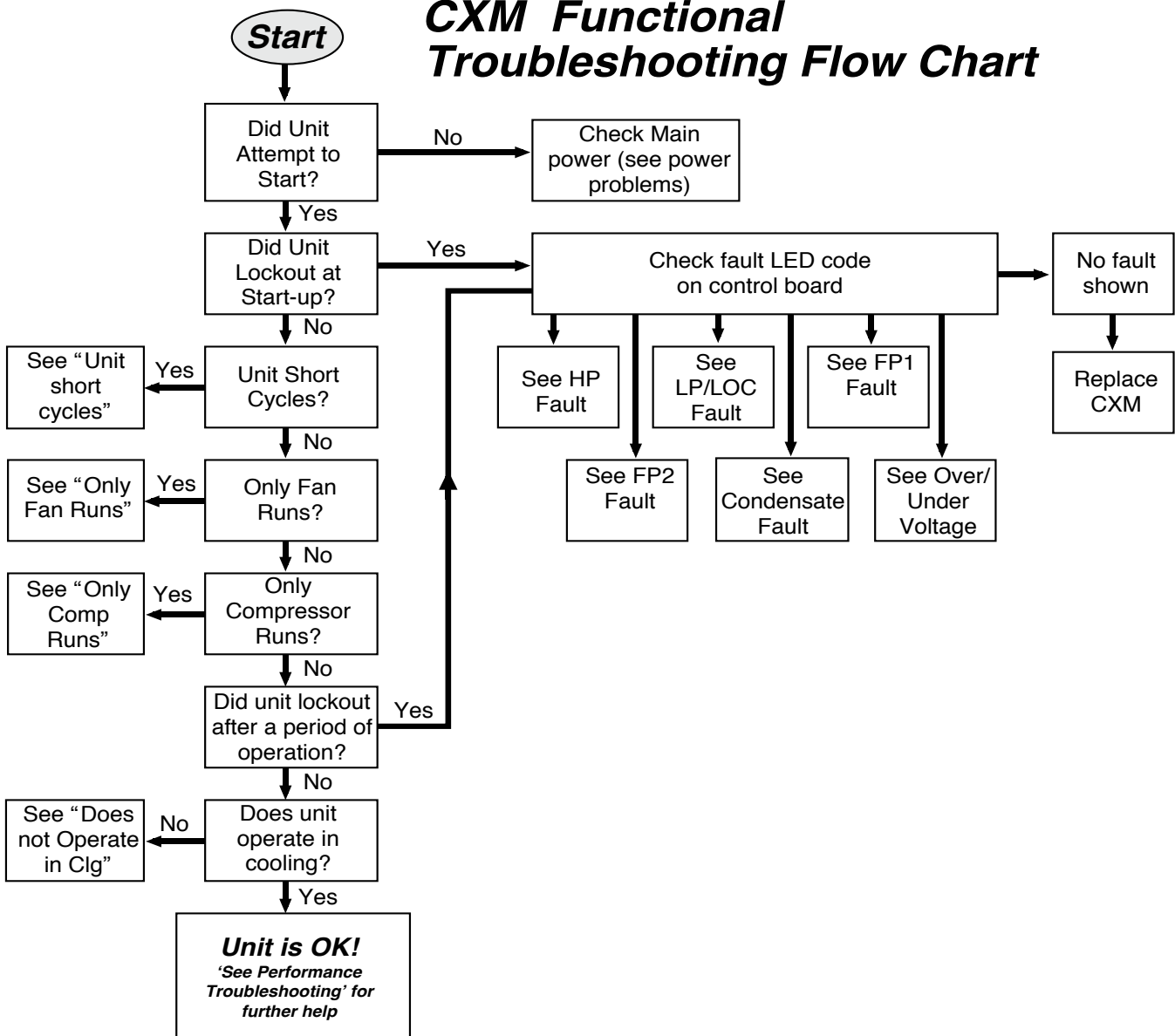

Functional Troubleshooting

Fault	Htg	Clg	Possible Cause	Solution
Main power Problems	X	X	Green Status LED Off	Check Line Voltage circuit breaker and disconnect Check for line voltage between L1 and L2 on the contactor Check for 24VAC between R and C on CXM/DXM Check primary/secondary voltage on transformer
	HP Fault-Code 2 High pressure	X	Reduced or no water flow in cooling	Check pump operation or valve operation/setting Check water flow adjust to proper flow rate
		X	Water Temperature out of range in cooling	Bring water temp within design parameters
		X	Reduced or no Air flow in heating	Check for dirty air filter and clean or replace Check fan motor operation and airflow restrictions Dirty Air Coil- construction dust etc. Too high of external static. Check static vs blower table
X		Air Temperature out of range in heating	Bring return air temp within design parameters	
X		X	Overcharged with refrigerant	Check superheat/subcooling vs typical operating condition table
X		X	Bad HP Switch	Check switch continuity and operation. Replace
LP/LOC Fault-Code 3 Low Pressure/Loss of Charge	X	X	Insufficient charge	Check for refrigerant leaks
	X		Compressor pump down at start-up	Check charge and start-up water flow
FP1 Fault - Code 4 Water Coil low temperature limit	X		Reduced or no water flow in heating	Check pump operation or water valve operation/setting Plugged strainer or filter. Clean or replace. Check water flow adjust to proper flow rate
	X		Inadequate anti-freeze level	Check antifreeze density with hydrometer
	X		Improper temperature limit setting (30°F vs 10°F [-1°C vs -12°C])	Clip JW3 jumper for antifreeze (10°F [-12°C]) use
	X		Water Temperature out of range	Bring water temp within design parameters
	X	X	Bad thermistor	Check temp and impedance correlation per chart
	FP2 fault - Code 5 Air Coil low temperature limit		X	Reduced or no Air flow in cooling
		X	Air Temperature out of range	Too much cold vent air? Bring entering air temp within design parameters
		X	Improper temperature limit setting (30°F vs 10°F [-1°C vs -12°C])	Normal airside applications will require 30°F [-1°C] only
X		X	Bad thermistor	Check temp and impedance correlation per chart
Condensate Fault-Code 6	X	X	Blocked Drain	Check for blockage and clean drain
	X	X	Improper trap	Check trap dimensions and location ahead of vent
		X	Poor Drainage	Check for piping slope away from unit Check slope of unit toward outlet Poor venting. Check vent location
		X	Moisture on sensor	Check for moisture shorting to air coil
	X	X	Plugged Air Filter	Replace Air Filter
	X	X	Restricted Return Air Flow	Find & eliminate restriction. Increase return duct and/or grille size.
	Over/Under Voltage-Code 7 (Auto resetting)	X	X	Under Voltage
X		X	Over Voltage	Check power supply voltage and 24VAC before and during operation. Check 24VAC and unit transformer tap for correct power supply voltage
Unit Performance Sentinel-Code 8	X		Heating mode FP2>125°F [52°C]	Check for poor air flow or overcharged unit.
		X	Cooling Mode FP1>125°F [52°C] OR FP2<40°F [4°C]	Check for poor water flow, or air flow
No Fault Code Shown	X	X	No compressor operation	See "Only fan operates"
	X	X	Compressor Overload	Check and Replace if necessary
	X	X	Control board	Reset power and check operation
Unit Short Cycles	X	X	Dirty Air Filter	Check and Clean air filter
	X	X	Unit in "Test Mode"	Reset power or wait 20 minutes for auto exit.
	X	X	Unit selection	Unit may be oversized for space. Check sizing for actual load of space.
	X	X	Compressor Overload	Check and Replace if necessary
Only Fan Runs	X	X	Thermostat position	Insure thermostat set for heating or cooling operation
	X	X	Unit locked out	Check for lockout codes. Reset power.
	X	X	Compressor Overload	Check compressor overload. Replace if necessary.
	X	X	Thermostat wiring	Check thermostat wiring at heat pump. Jumper Y and R for compressor operation in test mode.

Functional Troubleshooting

Fault	Htg	Clg	Possible Cause	Solution
Main power Problems	X	X	Green Status LED Off	Check Line Voltage circuit breaker and disconnect Check for line voltage between L1 and L2 on the contactor Check for 24VAC between R and C on CXM/DXM Check primary/secondary voltage on transformer
		X	Reduced or no water flow in cooling	Check pump operation or valve operation/setting Check water flow adjust to proper flow rate
HP Fault-Code 2 High pressure		X	Water Temperature out of range in cooling	Bring water temp within design parameters
	X		Reduced or no Air flow in heating	Check for dirty air filter and clean or replace Check fan motor operation and airflow restrictions Dirty Air Coil- construction dust etc. Too high of external static. Check static vs blower table
	X		Air Temperature out of range in heating	Bring return air temp within design parameters
	X	X	Overcharged with refrigerant	Check superheat/subcooling vs typical operating condition table
	X	X	Bad HP Switch	Check switch continuity and operation. Replace
	X	X	Insufficient charge	Check for refrigerant leaks
LP/LOC Fault-Code 3 Low Pressure/Loss of Charge	X		Compressor pump down at start-up	Check charge and start-up water flow

Performance Troubleshooting

Performance Troubleshooting	Htg	Clg	Possible Cause	Solution
Insufficient capacity/ Not cooling or heating properly	X	X	Dirty Filter	Replace or clean
	X		Reduced or no Air flow in heating	Check for dirty air filter and clean or replace Check fan motor operation and airflow restrictions Too high of external static. Check static vs blower table
		X	Reduced or no Air flow in cooling	Check for dirty air filter and clean or replace Check fan motor operation and airflow restrictions Too high of external static. Check static vs blower table
	X	X	Leaky duct work	Check supply and return air temperatures at the unit and at distant duct registers if significantly different, duct leaks are present
	X	X	Low refrigerant charge	Check superheat and subcooling per chart
	X	X	Restricted metering device	Check superheat and subcooling per chart. Replace.
		X	Defective Reversing Valve	Perform RV touch test
	X	X	Thermostat improperly located	Check location and for air drafts behind stat
	X	X	Unit undersized	Recheck loads & sizing check sensible clg load and heat pump capacity
	X	X	Scaling in water heat exchanger	Perform Scaling check and clean if necessary
	X	X	Inlet Water too Hot or Cold	Check load, loop sizing, loop backfill, ground moisture.
	High Head Pressure	X		Reduced or no Air flow in heating
		X	Reduced or no water flow in cooling	Check pump operation or valve operation/setting Check water flow adjust to proper flow rate
		X	Inlet Water too Hot	Check load, loop sizing, loop backfill, ground moisture.
X			Air Temperature out of range in heating	Bring return air temp within design parameters
		X	Scaling in water heat exchanger	Perform Scaling check and clean if necessary
X		X	Unit Overcharged	Check superheat and subcooling. Reweigh in charge
X		X	Non-condensables in system	Vacuum system and reweigh in charge
Low Suction Pressure	X		Reduced water flow in heating	Check pump operation or water valve operation/setting Plugged strainer or filter. Clean or replace. Check water flow adjust to proper flow rate
	X		Water Temperature out of range	Bring water temp within design parameters
		X	Reduced Air flow in cooling	Check for dirty air filter and clean or replace Check fan motor operation and airflow restrictions Too high of external static. Check static vs blower table
		X	Air Temperature out of range	Too much cold vent air? Bring entering air temp within design parameters
	X	X	Insufficient charge	Check for refrigerant leaks
Low discharge air temperature in heating	X		Too high of air flow	Check fan motor speed selection and airflow chart
	X		Poor Performance	See 'Insufficient Capacity'
High humidity		X	Too high of air flow	Check fan motor speed selection and airflow chart
		X	Unit oversized	Recheck loads & sizing check sensible clg load and heat pump capacity

Troubleshooting Form

Customer: _____ Antifreeze: _____
 Model#: _____ Serial#: _____ Loop type: _____
 Complaint: _____

HEATING CYCLE ANALYSIS -

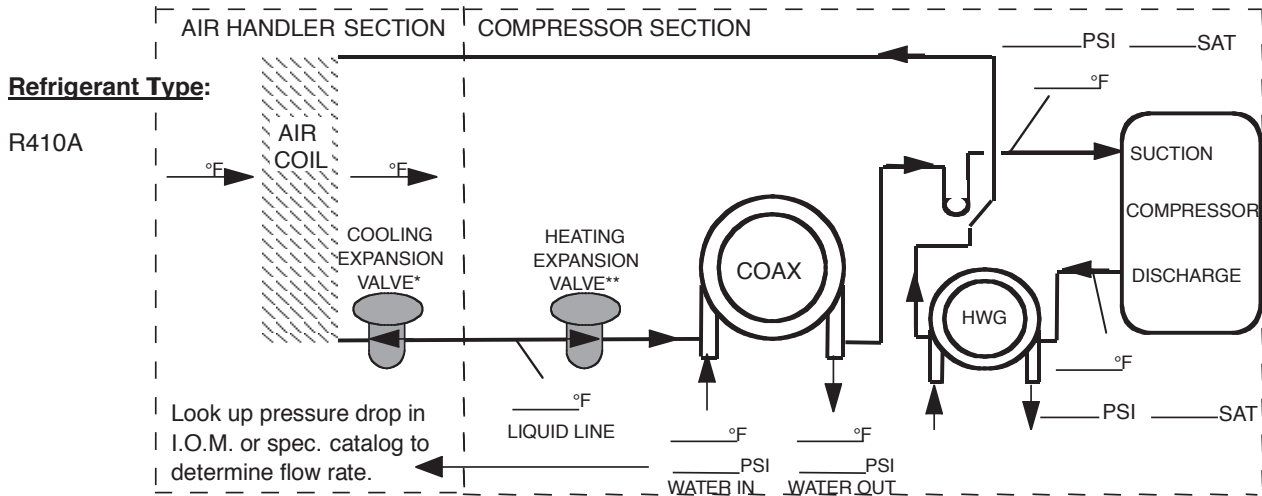

COOLING CYCLE ANALYSIS -

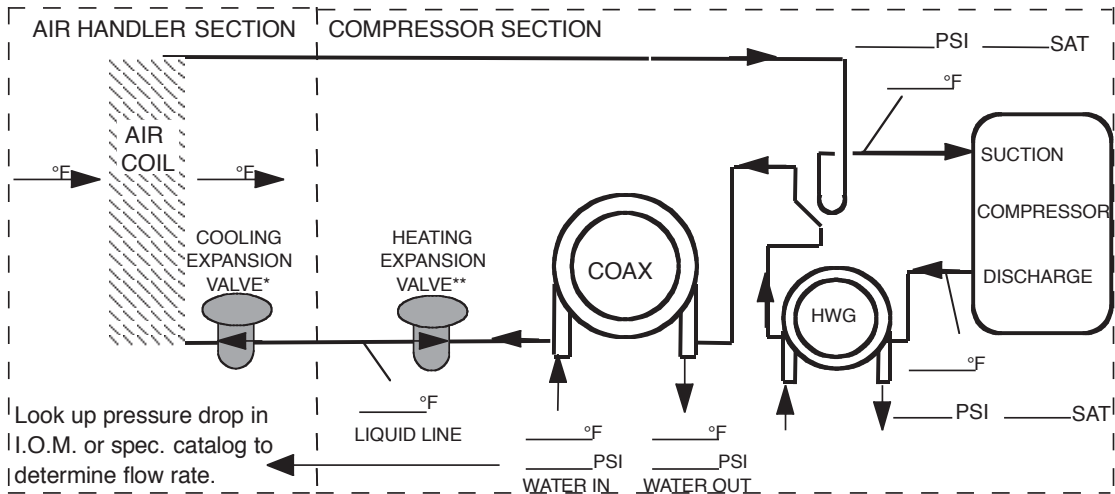

*Cooling expansion valve meters in the cooling mode, and bypasses in the heating mode.
 **Heating expansion valve meters in the heating mode, and bypasses in the cooling mode.

Heat of Extraction (Absorbion) or Heat of Rejection =

$$\text{_____ flow rate (gpm) x _____ temp. diff. (deg. F) x _____ fluid factor } \dagger = \text{_____ (Btu/hr)}$$

Superheat = suction temperature - suction saturation temp. = _____ (deg F)

Subcooling = discharge saturation temp. - liquid line temp. = _____ (deg F)

†Use 500 for water, 485 for antifreeze.

Note: Never connect refrigerant gauges during startup procedures. Conduct water-side analysis using P/T ports to determine water flow and temperature difference. If water-side analysis shows poor performance, refrigerant troubleshooting may be required. Connect refrigerant gauges as a last resort.

Revision History

Date	Page #	Description
16 Dec., 09	28	HWG Water Piping Size and Length Table Added
9 Dec., 09	11-12	Pump Curve Tables Added
30 Oct., 09	46-47	Functional Troubleshooting Table Updated
15 Sept., 09	36	'Safety Features - CXM/DXM Controls' Section Updated
13 August, 09	All	First Published

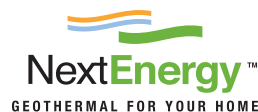

97B0047N02

97B0047N02

35 Earl Martin Dr.
Elmira, ON N3B 3L4

t: 1-800-367-9810
f: 1-877-684-3112
www.nextenergy.ca

ClimateMaster works continually to improve its products. As a result, the design and specifications of each product at the time for order may be changed without notice and may not be as described herein. Please contact ClimateMaster's Customer Service Department at 1-405-745-6000 for specific information on the current design and specifications. Statements and other information contained herein are not express warranties and do not form the basis of any bargain between the parties, but are merely ClimateMaster's opinion or commendation of its products.

The management system governing the manufacture of ClimateMaster's products is ISO 9001:2000 certified.