

Tranquility
Medium Temperature
Water-to-Water
(TMW) Series



Residential EarthPure[®]
Water-to-Water
Water-Source Heat Pumps
Installation, Operation &
Maintenance Instructions
97B0068N01
Rev.: 30 Oct., 2009B



Table of Contents

Model Nomenclature	3
Storage	5
Pre-Installation	5
Physical Data	6
Dimensional Data	7
Water Connection Installation	8
Ground Loop Applications	9-10
Ground Water Applications	11-12
Water Quality Standards	13
Load Plumbing Installation	14
Hot Water Generator	15-16
Electrical - Line Voltage	17
Electrical - Low Voltage Wiring	18-19
Electrical - Accessories	19
Water Valve Wiring	19
Electrical Wiring Schematics	20-21
CXM Controls	22
CXM Safety Control Reset	23-24
Unit Commissioning and Operating Conditions	24
Unit and System Checkout Procedure	25
Start Up Procedure	26-27
Operating Pressures	27-28
Preventive Maintenance	29
Warranty	30
Refrigeration Troubleshooting Form	31
Revision History	34

Model Nomenclature

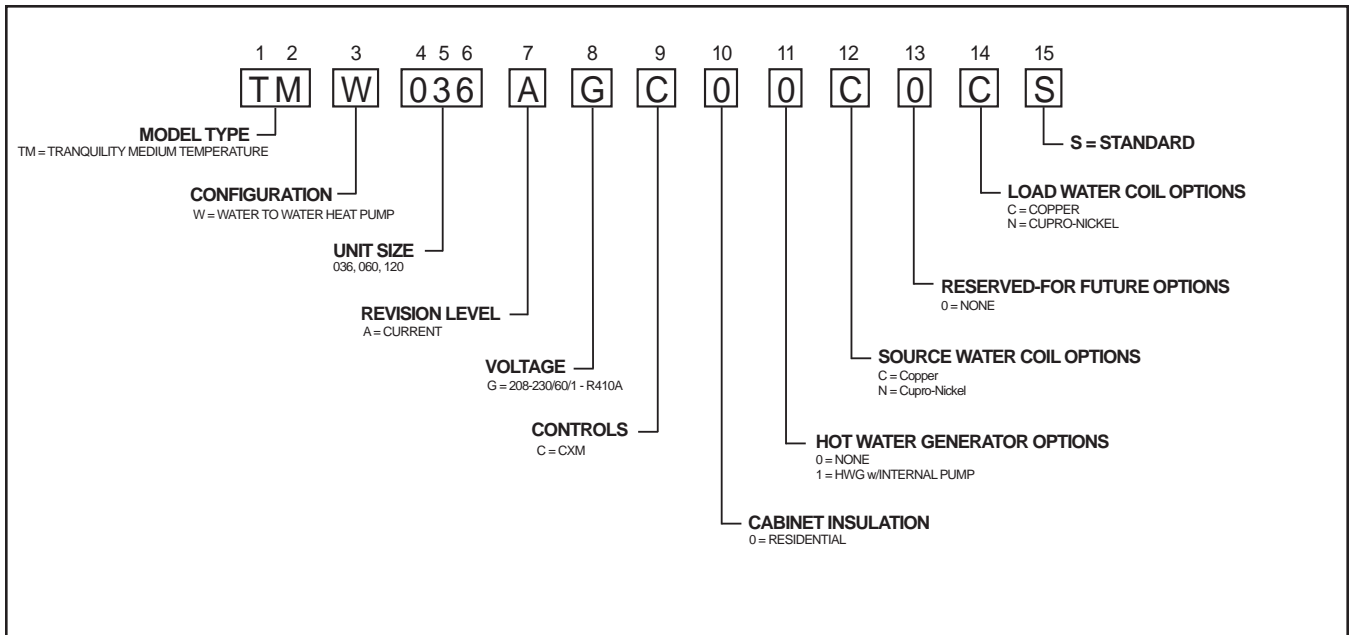

General Information

Safety

Warnings, cautions and notices appear throughout this manual. Read these items carefully before attempting any installation, service or troubleshooting of the equipment.

DANGER: Indicates an immediate hazardous situation, which if not avoided will result in death or serious injury. DANGER labels on unit access panels must be observed.

WARNING: Indicates a potentially hazardous situation, which if not avoided could result in death or serious injury.

CAUTION: Indicates a potentially hazardous situation or an unsafe practice, which if not avoided could result in minor or moderate injury or product or property damage.

NOTICE: Notification of installation, operation or maintenance information, which is important, but which is not hazard-related.

⚠ WARNING! ⚠

WARNING! To avoid the release of refrigerant into the atmosphere, the refrigerant circuit of this unit must be serviced only by technicians who meet local, state, and federal proficiency requirements.

⚠ WARNING! ⚠

WARNING! All refrigerant discharged from this unit must be recovered WITHOUT EXCEPTION. Technicians must follow industry accepted guidelines and all local, state, and federal statutes for the recovery and disposal of refrigerants. If a compressor is removed from this unit, refrigerant circuit oil will remain in the compressor. To avoid leakage of compressor oil, refrigerant lines of the compressor must be sealed after it is removed.

⚠ CAUTION! ⚠

CAUTION! To avoid equipment damage, DO NOT use these units as a source of heating or cooling during the construction process. The mechanical components and filters will quickly become clogged with construction dirt and debris, which may cause system damage.

General Information

Inspection

Upon receipt of the equipment, carefully check the shipment against the bill of lading. Make sure all units have been received. Inspect the carton or crating of each unit, and inspect each unit for damage. Assure the carrier makes proper notation of any shortages or damage on all copies of the freight bill and completes a common carrier inspection report. Concealed damage not discovered during unloading must be reported to the carrier within 15 days of receipt of shipment. **If not filed within 15 days, the freight company can deny the claim without recourse.** **Note: It is the responsibility of the purchaser to file all necessary claims with the Brya.** Notify the ClimateMaster Traffic Department of all damage within fifteen (15) days of shipment.

Storage

Equipment should be stored in its original packaging in a clean, dry area. Store units in an upright position at all times. The stack limit for TMW036, 060 and 120 is three.

Unit Protection

Cover units on the job site with either shipping packaging, vinyl film, or an equivalent protective covering. Cap the open ends of pipes stored on the job site. In areas where painting, plastering, and/or spraying has not been completed, all due precautions must be taken to avoid physical damage to the units and contamination by foreign material. Physical damage and contamination may prevent proper start-up and may result in costly equipment clean-up.

Examine all pipes, fittings, and valves before installing any of the system components. Remove any dirt or trash found in or on these components.

Pre-Installation

Installation, Operation, and Maintenance instructions are provided with each unit. The installation site chosen should include adequate service clearance around the unit. Before unit start-up, read all manuals and become familiar with the unit and its operation. Thoroughly check the system before operation.

Prepare units for installation as follows:

1. Compare the electrical data on the unit nameplate with ordering and shipping information to verify that the correct unit has been shipped.
2. Keep the cabinet covered with the shipping packaging until installation is complete and all plastering, painting, etc. is finished.
3. Verify refrigerant tubing is free of kinks or dents and that it does not touch other unit components.
4. Inspect all electrical connections. Connections must be clean and tight at the terminals.

⚠ CAUTION! ⚠

CAUTION! DO NOT store or install units in corrosive environments or in locations subject to temperature or humidity extremes (e.g., attics, garages, rooftops, etc.). Corrosive conditions and high temperature or humidity can significantly reduce performance, reliability, and service life. Always move and store units in an upright position. Tilting units on their sides may cause equipment damage.

⚠ CAUTION! ⚠

CAUTION! CUT HAZARD - Failure to follow this caution may result in personal injury. Sheet metal parts may have sharp edges or burrs. Use care and wear appropriate protective clothing, safety glasses and gloves when handling parts and servicing heat pumps.

NOTICE! Failure to remove shipping brackets from spring-mounted compressors will cause excessive noise, and could cause component failure due to added vibration.

Unit Physical Data

Model	036	060	120
Compressor (qty)	Scroll (1)		Scroll (2)
Factory Charge R410A (lbs) [kg] Per Circuit	4.5 [2.04]	6.25 [2.83]	6.25 [2.83]
Water Connection Size			
Source/Load	1" Swivel		1-1/2 IPT
HWG (in)	1" Swivel		1/2" IPT
Weight - Operating (lbs) [kg]	348 [158]	360 [163]	726 [329]
Weight - Packaged (lbs) [kg]	373 [169]	385 [175]	770 [349]
Water Volume (Source)			
Gallons (Liters)	0.96 (3.64)	1.33 (5.04)	2.65 (10.02)

Dual isolated compressor mounting
 Balanced port expansion valve (TXV)
 Insulated Source and Load Water Coils standard
 Insulated Refrigerant Circuit standard
 Compressor on (green) and fault (red) light

TMW036 - 120 Unit Dimensional Data

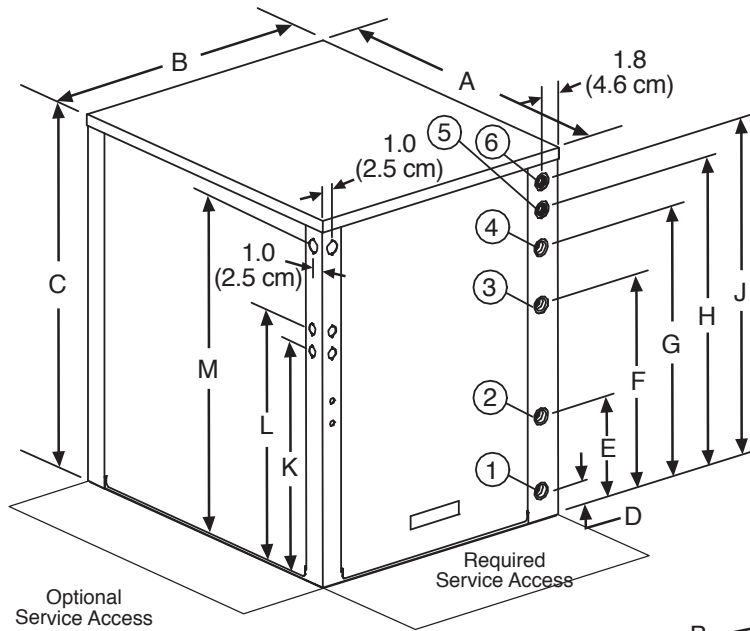

- Notes:
1. Front & side access is preferred for service access. However, all components may be serviced from the front access panel if side access is not available.
 2. While clear access to all removable panels is not required, installer should take care to comply with all building codes and allow adequate clearance for future field services.

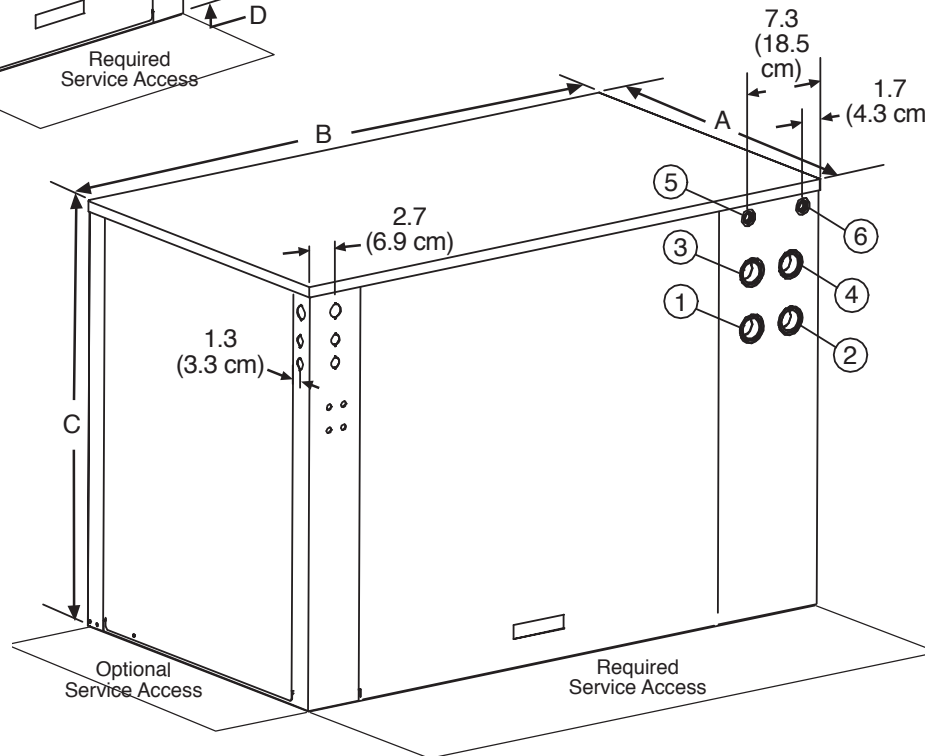

Water to Water	Overall Cabinet			Water Connections						Electric Access Plugs			
	A	B	C	1	2	3	4	5	6	K	L	M	
	Depth	Width	Height	D Source (Outdoor) Water In	E Source (Outdoor) Water Out	F Load (Indoor) Water In	G Load (Indoor) Water Out	H HWG Return In	J HWG Water Out	Low Voltage	External Pump	Power Supply	
036-060	in.	30.6	25.4	33	2.7	9.4	19.4	24.5	27.9	30.4	20.9	22.9	30.9
	cm.	77.8	64.5	83.8	6.9	23.9	49.3	62.2	70.9	77.2	53.1	58.2	78.5
120	in.	30.6	52.9	37	25.2	25.2	30.1	30.1	34.9	34.9	29.9	31.9	34.4
	cm.	77.8	134.4	94	64.0	64.0	76.5	76.5	88.6	88.6	75.9	81.0	87.4

Unit Installation

TMW Unit Location

These units are not designed for outdoor installation. Locate the unit in an INDOOR area that allows enough space for service personnel to perform typical maintenance or repairs.

The installation of water source heat pump units and all associated components, parts and accessories which make up the installation shall be in accordance with the regulations of ALL authorities having jurisdiction and MUST conform to all applicable codes. It is the responsibility of the Installing Contractor to determine

and comply with ALL applicable codes and regulations.

Locate the unit in an indoor area that allows easy removal of access panels, and has enough space for service personnel to perform maintenance or repair. Provide sufficient room to make water and electrical connections.. Any access panel screws that would be difficult to remove after the unit is installed should be removed prior to setting the unit. These units are not approved for outdoor installation and, therefore, must be installed inside the structure being conditioned. Do not locate in areas subject to freezing or where humidity levels can cause cabinet condensation.

WATER CONNECTION INSTALLATION

Residential models using swivel piping fittings for water connections are rated for 450 psi (3101 kPa) operating pressure. The connections have a rubber gasket seal similar to a garden hose gasket, which when mated to the flush end of most 1" threaded male pipe fittings provides a leak-free seal without the need for thread sealing tape or joint compound. Insure that the rubber seal is in the swivel connector prior to attempting any connection (rubber seals are shipped attached to the swivel connector). **DO NOT OVER TIGHTEN** or leaks may occur.

IPT Connections (Size 120)

Pipe joint compound is not necessary when Teflon threaded tape is pre-applied to hose assemblies or when flared-end connections are used. If pipe joint compound is preferred, use compound only in small amounts on the pipe threads of the fitting adapters. Prevent sealant from reaching the flared surfaces of the joint.

Note: When anti-freeze is used in the loop, assure that it is compatible with Teflon tape or pipe joint compound employed.

Maximum allowable torque for brass fittings is 30 ft-lbs [41 N-m]. If a torque wrench is not available, tighten finger-tight plus one quarter turn. Tighten steel fittings as necessary.

The female locking ring is threaded onto the pipe threads which holds the male pipe end against the rubber gasket, and seals the joint. **HAND TIGHTEN ONLY! DO NOT OVERTIGHTEN!**

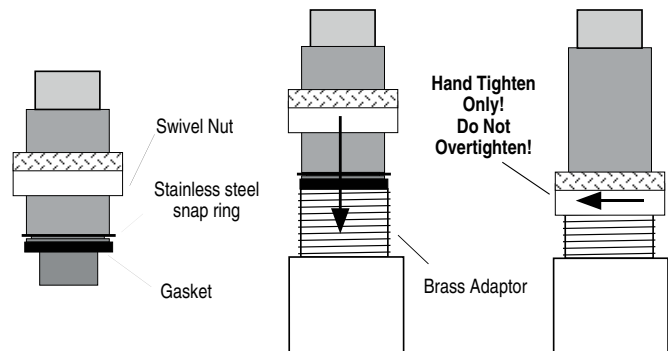

Ground-Loop Heat Pump Applications

⚠ CAUTION! ⚠

CAUTION! The following instructions represent industry accepted installation practices for closed loop earth coupled heat pump systems. Instructions are provided to assist the contractor in installing trouble free ground loops. These instructions are recommendations only. State/provincial and local codes **MUST** be followed and installation **MUST** conform to ALL applicable codes. It is the responsibility of the installing contractor to determine and comply with ALL applicable codes and regulations.

Pre-Installation

Prior to installation, locate and mark all existing underground utilities, piping, etc. Install loops for new construction before sidewalks, patios, driveways, and other construction has begun. During construction, accurately mark all ground loop piping on the plot plan as an aid in avoiding potential future damage to the installation.

Piping Installation

All earth loop piping materials should be limited to polyethylene fusion only for in-ground sections of the loop. Galvanized or steel fittings should not be used at any time due to their tendency to corrode. All plastic to metal threaded fittings should be avoided due to their potential to leak in earth coupled applications. A flanged fitting should be substituted. P/T plugs should be used so that flow can be measured using the pressure drop of the unit heat exchanger. Earth loop temperatures can range between 25 and 110°F [-4 to 43°C]. Flow rates between 2.25 and 3 gpm per ton [2.41 to 3.23 l/m per kW] of cooling capacity is recommended in these applications.

Test individual horizontal loop circuits before backfilling. Test vertical U-bends and pond loop assemblies prior to installation. Pressures of at least 100 psi [689 kPa] should be used when testing. Do not exceed the pipe pressure rating. Test entire system when all loops are assembled.

Flushing the Earth Loop

Once piping is completed between the unit, the flow controller and the ground loop (Figure 1), the loop is ready for final purging and charging. A flush cart with at least a 1.5 hp [1.1 kW] pump is required to achieve enough fluid velocity in the loop piping system to purge air and dirt particles. An antifreeze solution is used in most areas to prevent freezing. All air and debris must be removed from the earth loop piping before operation. Flush the loop with a high volume of water at a minimum velocity of 2 fps (0.6 m/s) in all piping. The steps below must be followed for proper flushing.

1. Fill loop with water from a garden hose through the flush cart before using the flush cart pump to insure an even fill.

2. Once full, the flushing process can begin. Do not allow the water level in the flush cart tank to drop below the pump inlet line to avoid air being pumped back out to the earth loop.
3. Try to maintain a fluid level in the tank above the return tee so that air cannot be continuously mixed back into the fluid. Surges of 50 psi (345 kPa) can be used to help purge air pockets by simply shutting off the return valve going into the flush cart reservoir. This “dead heads” the pump to 50 psi (345 kPa). To purge, dead head the pump until maximum pumping pressure is reached. Open the return valve and a pressure surge will be sent through the loop to help purge air pockets from the piping system.
4. Notice the drop in fluid level in the flush cart tank when the return valve is shut off. If air is adequately purged from the system, the level will drop only 1-2 inches (2.5 - 5 cm) in a 10” (25 cm) diameter PVC flush tank (about a half gallon [2.3 liters]), since liquids are incompressible. If the level drops more than this, flushing should continue since air is still being compressed in the loop fluid. Perform the “dead head” procedure a number of times.
Note: This fluid level drop is your only indication of air in the loop.

Antifreeze may be added before, during or after the flushing procedure. However, depending upon which time is chosen, antifreeze could be wasted when emptying the flush cart tank. See antifreeze section for more details.

Loop static pressure will fluctuate with the seasons. Pressures will be higher in the winter months than during the cooling season. This fluctuation is normal and should be considered when charging the system initially. Run the unit in either heating or cooling for a number of minutes to condition the loop to a homogenous temperature. This is a good time for tool cleanup, piping insulation, etc. Then, perform final flush and pressurize the loop to a static pressure of 50-75 psi [345-517 kPa] (winter) or 35-40 psi [241-276 kPa] (summer). After pressurization, be sure to loosen the plug at the end of the Grundfos loop pump motor(s) to allow trapped air to be discharged and to insure the motor housing has been flooded. This is not required for Taco circulators. Insure that the Flow Controller provides adequate flow through the unit by checking pressure drop across the heat exchanger and compare to the pressure drop tables at the back of the manual.

Antifreeze

In areas where minimum entering loop temperatures drop below 40°F [5°C] or where piping will be routed through areas subject to freezing, antifreeze is required. Alcohols and glycols are commonly used as antifreeze; however your local sales manager should be consulted for the antifreeze best suited to your area. Freeze protection should be maintained to 15°F [9°C] below the lowest expected entering loop temperature. For example, if 30°F [-1°C] is the minimum expected entering loop temperature, the leaving

Ground-Loop Heat Pump Applications

loop temperature would be 25 to 22°F [-4 to -6°C] and freeze protection should be at 15°F [-10°C]. Calculation is as follows:

$$30^{\circ}\text{F} - 15^{\circ}\text{F} = 15^{\circ}\text{F} \quad [-1^{\circ}\text{C} - 9^{\circ}\text{C} = -10^{\circ}\text{C}]$$

All alcohols should be premixed and pumped from a reservoir outside of the building when possible or introduced under the water level to prevent fumes. Calculate the total volume of fluid in the piping system using Table 1. Then use the percentage by volume shown in Table 2 for the amount of antifreeze needed. Antifreeze concentration should be checked from a well mixed sample using a hydrometer to measure specific gravity.

Low Water Temperature Cutout Setting - CXM Control

When antifreeze is selected, the FP1 jumper (JW3) should be clipped to select the low temperature (antifreeze 13°F [-10.6°C]) set point and avoid nuisance faults (see “Low Water Temperature Cutout Selection” in this manual).

Figure 1: Typical Ground-Loop Application

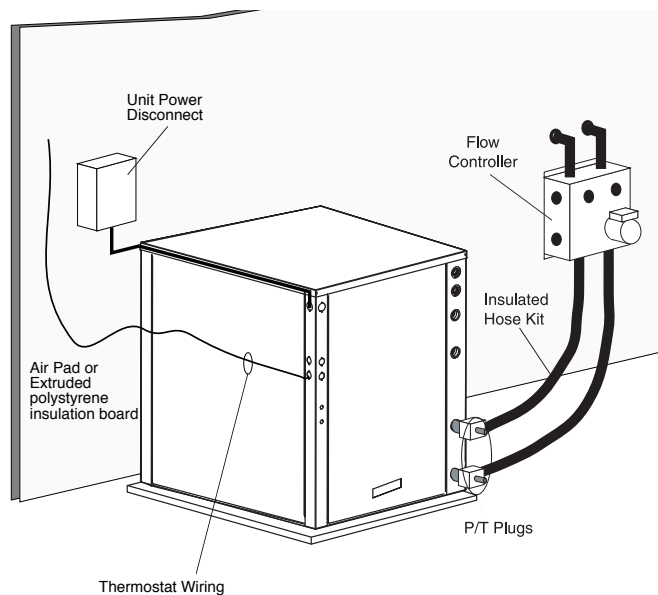

Table 1: Approximate Fluid Volume (gal.) per 100' of Pipe

Fluid Volume (gal [liters] per 100' [30 meters] Pipe)		
Pipe	Size	Volume (gal) [liters]
Copper	1"	4.1 [15.3]
	1.25"	6.4 [23.8]
	2.5"	9.2 [34.3]
Rubber Hose	1"	3.9 [14.6]
Polyethylene	3/4" IPS SDR11	2.8 [10.4]
	1" IPS SDR11	4.5 [16.7]
	1.25" IPS SDR11	8.0 [29.8]
	1.5" IPS SDR11	10.9 [40.7]
	2" IPS SDR11	18.0 [67.0]
	1.25" IPS SCH40	8.3 [30.9]
	1.5" IPS SCH40	10.9 [40.7]
	2" IPS SCH40	17.0 [63.4]
Unit Heat Exchanger	Typical	1.0 [3.8]
Flush Cart Tank	10" Dia x 3ft tall [254mm x 91.4cm tall]	10 [37.9]

Table 2: Antifreeze Percentages by Volume

Type	Minimum Temperature for Low Temperature Protection			
	10°F [-12.2°C]	15°F [-9.4°C]	20°F [-6.7°C]	25°F [-3.9°C]
Methanol	25%	21%	16%	10%
100% USP food grade Propylene Glycol	38%	25%	22%	15%
Ethanol*	29%	25%	20%	14%

* Must not be denatured with any petroleum based product

Ground-Water Heat Pump Applications

Open Loop - Ground Water Systems

Shut off valves should be included for ease of servicing. Boiler drains or other valves should be “tee’d” into the lines to allow acid flushing of the heat exchanger. Shut off valves should be positioned to allow flow through the coaxial heat exchanger via the boiler drains without allowing flow into the piping system. P/T plugs should be used so that pressure drop and temperature can be measured. Piping materials should be limited to copper or PVC SCH80. Note: Due to the pressure and temperature extremes, PVC SCH40 is not recommended.

Water quantity should be plentiful and of good quality. Consult water quality table for guidelines. The unit can be ordered with either a copper or cupro-nickel water heat exchanger. Consult table 3 for recommendations. Copper is recommended for closed loop systems and open loop ground water systems that are not high in mineral content or corrosiveness. In conditions anticipating heavy scale formation or in brackish water, a cupro-nickel heat exchanger is recommended. In ground water situations where scaling could be heavy or where biological growth such as iron bacteria will be present, an open loop system is not recommended. Heat exchanger coils may over time lose heat exchange capabilities due to build up of mineral deposits. Heat exchangers must only be serviced by a qualified technician, as acid and special pumping equipment is required. Desuperheater coils can likewise become scaled and possibly plugged. In areas with extremely hard water, the owner should be informed that the heat exchanger may require occasional acid flushing. In some cases, the desuperheater option should not be recommended due to hard water conditions and additional maintenance required.

Water Quality Standards

Scaling potential should be assessed using the pH/ Calcium hardness method. If the pH <7.5 and the Calcium hardness is less than 100 ppm, scaling potential is low. If this method yields numbers out of range of those listed, the Ryznar Stability and Langelier Saturation indices should be calculated. Use the appropriate scaling surface temperature for the application, 150°F [66°C] for direct use (well water/ open loop) and HWG (desuperheater); 85°F [29°C] for indirect use. A monitoring plan should be implemented in these probable scaling situations. Other water quality issues such as iron fouling, corrosion prevention and erosion and clogging should also be considered.

Expansion Tank and Pump

Use a closed, bladder-type expansion tank to minimize mineral formation due to air exposure. The expansion tank should be sized to provide at least one minute continuous run time of the pump using its drawdown capacity rating to prevent pump short cycling. Discharge water from the unit is not contaminated in any manner and can be disposed of in various ways, depending on local building codes (e.g. recharge well, storm sewer, drain field, adjacent stream or pond, etc.). Most local codes forbid the use of sanitary

sewer for disposal. Consult your local building and zoning department to assure compliance in your area.

The pump should be sized to handle the home's domestic water load (typically 5-9 gpm [23-41 l/m]) plus the flow rate required for the heat pump. Pump sizing and expansion tank must be chosen as complimentary items. For example, an expansion tank that is too small can causing premature pump failure due to short cycling. Variable speed pumping applications should be considered for the inherent energy savings and smaller expansion tank requirements.

Water Control Valve

Always maintain water pressure in the heat exchanger by placing the water control valve(s) on the discharge line to prevent mineral precipitation during the off-cycle. Pilot operated slow closing valves are recommended to reduce water hammer. If water hammer persists, a mini-expansion tank can be mounted on the piping to help absorb the excess hammer shock. Insure that the total 'VA' draw of the valve can be supplied by the unit transformer. For instance, a slow closing valve can draw up to 35VA. This can overload smaller 40 or 50 VA transformers depending on the other controls in the circuit. A typical pilot operated solenoid valve draws approximately 15VA. Note the special wiring diagrams later in this manual for slow closing valves.

Flow Regulation

Flow regulation can be accomplished by two methods. One method of flow regulation involves simply adjusting the ball valve or water control valve on the discharge line. Measure the pressure drop through the unit heat exchanger, and determine flow rate from tables located later in this manual. Since the pressure is constantly varying, two pressure gauges may be needed. Adjust the valve until the desired flow of 1.5 to 2 gpm per ton [2.0 to 2.6 l/m per kW] is achieved. A second method of flow control requires a flow control device mounted on the outlet of the water control valve. The device is typically a brass fitting with an orifice of rubber or plastic material that is designed to allow a specified flow rate. On occasion, flow control devices may produce velocity noise that can be reduced by applying some back pressure from the ball valve located on the discharge line. Slightly closing the valve will spread the pressure drop over both devices, lessening the velocity noise. **NOTE: When EWT is below 50°F [10°C], a minimum of 2 gpm per ton (2.6 l/m per kW) is required.**

Water Coil Low Temperature Limit Setting

For all open loop systems the 30°F [-1.1°C] FP1 setting (factory setting-water) should be used to avoid freeze damage to the unit. See “Low Water Temperature Cutout Selection” in this manual for details on the low limit setting.

Ground-Water Heat Pump Applications

⚠ CAUTION! ⚠

CAUTION! Many units are installed with a factory or field supplied manual or electric shut-off valve. **DAMAGE WILL OCCUR** if shut-off valve is **closed** during unit operation. A high pressure switch must be installed on the heat pump side of any field provided shut-off valves and connected to the heat pump controls in series with the built-in refrigerant circuit high pressure switch to disable compressor operation if water pressure exceeds pressure switch setting. The field installed high pressure switch shall have a cut-out pressure of 300 psig and a cut-in pressure of 250 psig. This pressure switch can be ordered from ClimateMaster with a 1/4" internal flare connection as part number 39B0005N02.

⚠ CAUTION! ⚠

CAUTION! Refrigerant pressure activated water regulating valves should never be used with ClimateMaster equipment.

Figure 2: Typical Open Loop/ Well Application

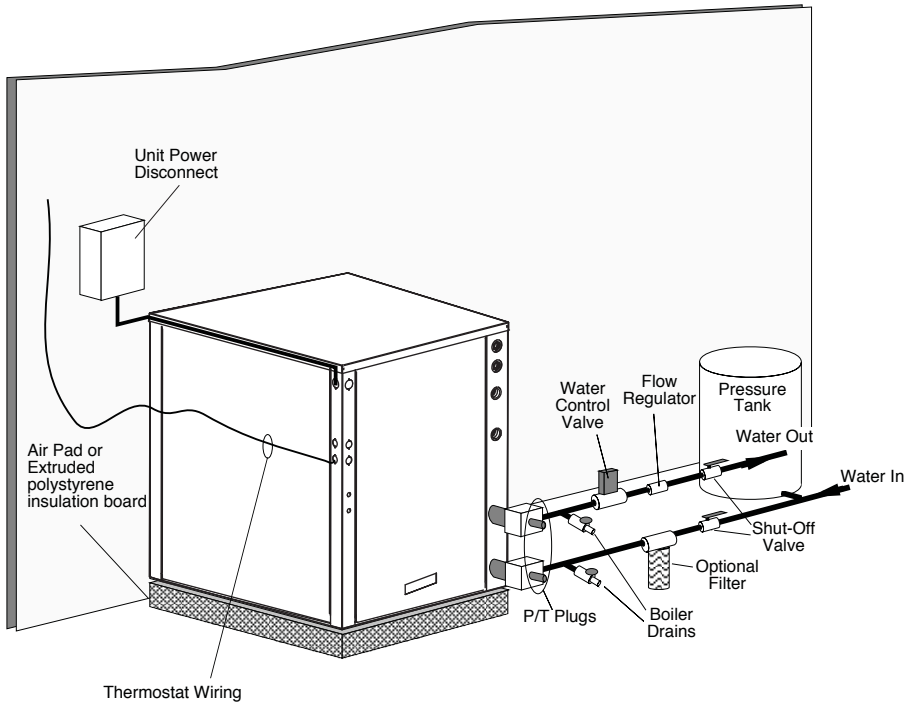

Water Quality Standards

Table 3: Water Quality Standards

Water Quality Parameter	HX Material	Closed Recirculating	Open Loop and Recirculating Well		
Scaling Potential - Primary Measurement					
Above the given limits, scaling is likely to occur. Scaling indexes should be calculated using the limits below					
pH/Calcium Hardness Method	All	-	pH < 7.5 and Ca Hardness <100ppm		
Index Limits for Probable Scaling Situations - (Operation outside these limits is not recommended)					
Scaling indexes should be calculated at 150°F [66°C] for direct use and HWG applications, and at 90°F [32°C] for indirect HX use. A monitoring plan should be implemented.					
Ryznar Stability Index	All	-	6.0 - 7.5 If >7.5 minimize steel pipe use.		
Langelier Saturation Index	All	-	-0.5 to +0.5 If <-0.5 minimize steel pipe use. Based upon 150°F [66°C] HWG and Direct well, 85°F [29°C] Indirect Well HX		
Iron Fouling					
Iron Fe ²⁺ (Ferrous) (Bacterial Iron potential)	All	-	<0.2 ppm (Ferrous) If Fe ²⁺ (ferrous)>0.2 ppm with pH 6 - 8, O ₂ <5 ppm check for iron bacteria		
Iron Fouling	All	-	<0.5 ppm of Oxygen Above this level deposition will occur.		
Corrosion Prevention					
pH	All	6 - 8.5 Monitor/treat as needed	6 - 8.5 Minimize steel pipe below 7 and no open tanks with pH <8		
Hydrogen Sulfide (H ₂ S)	All	-	<0.5 ppm At H ₂ S>0.2 ppm, avoid use of copper and copper nickel piping or HX's. Rotten egg smell appears at 0.5 ppm level. Copper alloy (bronze or brass) cast components are OK to <0.5 ppm.		
Ammonia ion as hydroxide, chloride, nitrate and sulfate compounds	All	-	<0.5 ppm		
Maximum Chloride Levels	Copper CuproNickel 304 SS 316 SS Titanium	- - - - -	Maximum Allowable at maximum water temperature.		
			50°F (10°C)	75°F (24°C)	100°F (38°C)
			<20ppm	NR	NR
			<150 ppm	NR	NR
			<400 ppm	<250 ppm	<150 ppm
<1000 ppm	<550 ppm	< 375 ppm			
>1000 ppm	>550 ppm	>375 ppm			
Erosion and Clogging					
Particulate Size and Erosion	All	<10 ppm of particles and a maximum velocity of 6 fps [1.8 m/s] Filtered for maximum 800 micron [800mm, 20 mesh] size.	<10 ppm (<1 ppm "sandfree" for reinjection) of particles and a maximum velocity of 6 fps [1.8 m/s]. Filtered for maximum 800 micron [800mm, 20 mesh] size. Any particulate that is not removed can potentially clog components.		

Rev.: 01/21/09B

- Notes:
- Closed Recirculating system is identified by a closed pressurized piping system.
 - Recirculating open wells should observe the open recirculating design considerations.
 - NR - Application not recommended.
 - "-" No design Maximum.

Load Side Plumbing Installation

TMW Unit Load Plumbing

The applications are too varied to describe in this document. However, some basic guidelines will be presented. Much of the discussions on water loop applications would be valid for the load plumbing discussion as well. All plumbing should conform to local codes with the following considerations:

Wide temperature variation applications such as heating/cooling coils:

- Employ piping materials that are rated for the maximum temperature and pressure combination. This excludes PVC for most heating applications.
- Insure that load water flow in high temperature heating applications is at least 3 gpm per ton [3.9 l/m per kW] to improve performance and reduce nuisance high pressure faults.
- DO NOT employ plastic to metal threaded joints
- Utilize a pressure tank and air separator vent system to equalize pressure and remove air.

Swimming Pool Hot Tub Applications:

- Load coax should be isolated with secondary heat exchanger constructed of anti-corrosion material in all chlorine/bromine fluid applications.

Potable Water Applications:

- Load coax material should always be vented double walled for use in potable water systems.
- Insure load water flow in high temperature heating applications is at least 3 gpm per ton to improve performance and reduce nuisance to high pressure faults.

NOTE: ClimateMaster strongly recommends all piping connections, both internal and external to the unit, be pressure tested by an appropriate method prior to any finishing of the interior space or before access to all connections is limited. Test pressure may not exceed the maximum allowable pressure for the unit and all components within the water system. ClimateMaster will not be responsible or liable for damages from water leaks due to inadequate or lack of a pressurized leak test, or damages caused by exceeding the maximum pressure rating during installation.

Hot Water Generator

The HWG (Hot Water Generator) or desuperheater option provides considerable operating cost savings by utilizing excess heat energy from the heat pump to help satisfy domestic hot water requirements. The HWG is active throughout the year, providing virtually free hot water when the heat pump operates in the cooling mode or hot water at the COP of the heat pump during operation in the heating mode.

Heat pumps equipped with the HWG option include a built-in water to refrigerant heat exchanger that eliminates the need to tie into the heat pump refrigerant circuit in the field. The control circuit and pump are also built in for residential equipment. Figure 3 shows a typical example of HWG water piping connections on a unit with built-in pump. This piping layout minimizes scaling potential.

Electric water heaters are recommended. If a gas, propane, or oil water heater is used, a second preheat tank should be considered (Figure 4). Also, if the electric water heater has only a single center element, the dual tank system is recommended to insure a usable entering water temperature for the HWG.

Figure 3: Typical HWG Installation

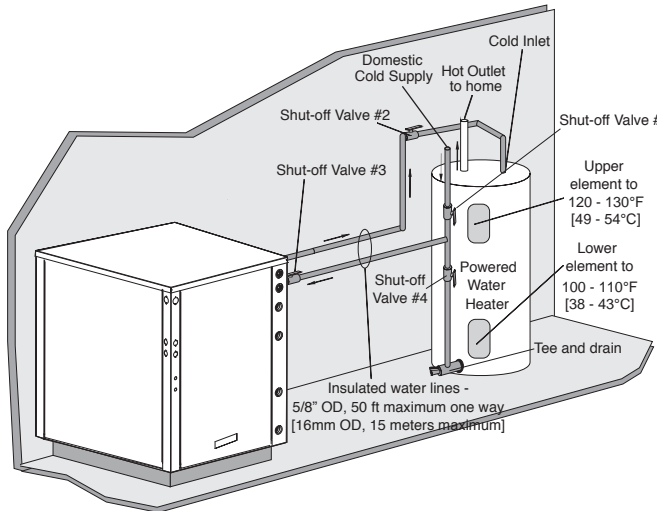

Typically a single tank of at least 52 gallons (235 liters) is used to limit installation costs and space. However, a dual tank, as shown in Figure 4, is the most efficient system, providing the maximum storage and temperate source water to the HWG.

It is always advisable to use water softening equipment on domestic water systems to reduce the scaling potential and lengthen equipment life. In extreme water conditions, it may be necessary to avoid the use of the HWG option since the potential cost of frequent maintenance may offset or exceed any savings.

R-410 systems inherently have a lower hot gas temperature than R-22 systems because the equipment is more efficient (i.e. less waste heat is available). It is possible that energy could be transferred from the water heater to the hot gas line instead of from the hot gas line to the water heater during certain times of the year. To prevent this from occurring, a temperature switch will deactivate the pump at those conditions that typically occur in the cooling mode with low entering water temperatures.

Figure 4: HWG Double Tank Installation

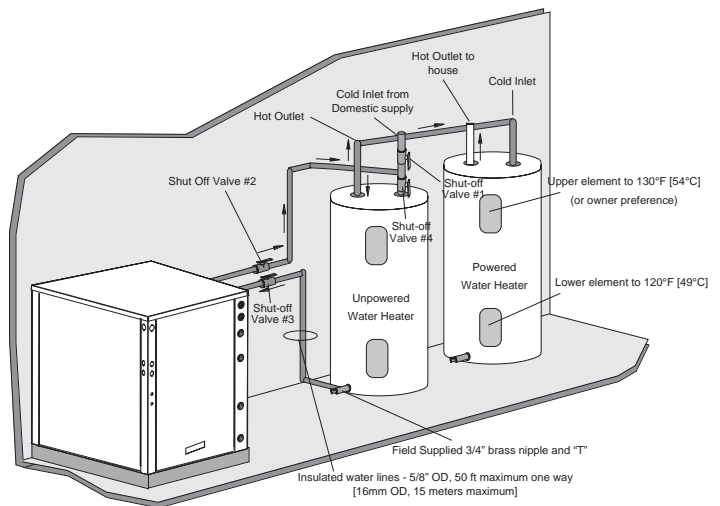

Hot Water Generator

Installation

The HWG high limit temperature switch is set at 125°F [52°C] and is located on the HWG heat exchanger “Water In” line. If the HWG is connected incorrectly or if circulation is reversed, the aquastat will sense leaving water temperature and prevent HWG operation. **UNDER NO CIRCUMSTANCES SHOULD THE LIMIT BE DISCONNECTED OR REMOVED!** Full load conditions could drive hot water tank temperatures far above safe temperature levels if the aquastat has been disconnected or removed.

The heat pump, water piping, pump, and hot water tank should be located where the ambient temperature is not subject to freezing. Keep water piping lengths at a minimum. **DO NOT** use a one way length greater than 50 ft. [15 m].

All installations must be in accordance with local codes. The installer is responsible for knowing the local requirements, and for performing the installation accordingly. **DO NOT** connect the pump wiring until “Initial Start-Up” section, below. Powering the pump before all installation steps are completed may damage the pump.

Water Tank Preparation

1. Turn off power or fuel supply to the hot water tank.
2. Connect a hose to the drain valve on the water tank.
3. Shut off the cold water supply to the water tank.
4. Open the drain valve and open the pressure relief valve or a hot water faucet to drain tank.
5. When using an existing tank, it should be flushed with cold water after it is drained until the water leaving the drain hose is clear and free of sediment.
6. Close all valves and remove the drain hose.
7. Install HWG water piping.

HWG Water Piping

1. Using at least 5/8” [16mm] O.D. copper, route and install the water piping, valves and air vent as shown in Figures 3 or 4. An appropriate method must be employed to purge air from the HWG piping. This may be accomplished by flushing water through the HWG (as In Figures 3 or 4).
2. Insulate all HWG water piping with no less than 3/8” [10mm] wall closed cell insulation.
3. Open both shut off valves and make sure the tank drain valve is closed.

Water Tank Refill

1. Close valve #4. Ensure that the HWG valves (valves #2 and #3) are open. Open the cold water supply (valve #1) to fill the tank through the HWG piping. This will purge air from the HWG piping.
2. Open a hot water faucet to vent air from the system until water flows from faucet; turn off faucet. Open valve #4.
3. Depress the hot water tank pressure relief valve handle to ensure that there is no air remaining in the tank.

4. Inspect all work for leaks.
5. Before restoring power or fuel supply to the water heater, adjust the temperature setting on the tank thermostat(s) to insure maximum utilization of the heat available from the refrigeration system and conserve the most energy. On tanks with both upper and lower elements and thermostats, the lower element should be turned down to 100°F [38°C] or the lowest setting; the upper element should be adjusted to 120-130°F [49-54°C]. Depending upon the specific needs of the customer, you may want to adjust the upper element differently. On tanks with a single thermostat, a preheat tank should be used (Fig 4).
6. Replace access cover(s) and restore power or fuel supply.

Initial Start-Up

1. Make sure all valves in the HWG water circuit are fully open.
2. Turn on the heat pump and allow it to run for 10-15 minutes.
3. Turn the heat pump and heat pump power supply “OFF” and **CONNECT POWER TO THE HWG PUMP** as shown in the unit wiring diagram. Connect the pump power lead as instructed on the tag attached to the pump wiring.
4. The HWG pump should not run if the compressor is not running.
5. The temperature difference between the water entering and leaving the HWG coil should be approximately 5-10°F [3-6°C].
6. Allow the unit to operate for 20 to 30 minutes to insure that it is functioning properly.

Electrical - Line Voltage

⚠ CAUTION! ⚠

Use only copper conductors for field installed electrical wiring. Unit terminals are not designed to accept other types of conductors.

General Line Voltage Wiring

Be sure the available power is the same voltage and phase as that shown on the unit serial plate. Line and low voltage wiring must be done in accordance with local codes or the National Electric Code, whichever is applicable.

TMW Power Connection

Line voltage connection is made by connecting the incoming line voltage wires to the power distribution block, or compressor contactor, refer to unit wiring diagram. Consult the electrical data table (Table 4) for correct fuse size.

208 Volt Operation

The units are factory wired for 230 Volt. The transformer may be switched to 208V operation as illustrated on the wiring diagram by switching the Red (208V) and the Orange (230V) at the contactor terminal L1.

⚠ WARNING! ⚠

Disconnect electrical power source to prevent injury or death from electrical shock.

⚠ WARNING! ⚠

To avoid possible injury or death due to electrical shock, open the power supply disconnect switch and secure it in an open position during installation.

All field installed wiring, including electrical ground, must comply with the National Electrical Code as well as all applicable local codes.

Refer to the unit wiring diagrams and electrical data table (Table 4) for fuse sizes and a schematic of the field connections which must be made by the installing (or electrical) contractor.

Consult the unit wiring diagram located on the inside of the compressor access panel to ensure proper electrical hookup. All final electrical connections must be made with a length of flexible conduit to minimize vibration and sound transmission to the building.

Electrical Data

Table 4: TMW Electrical Data

Model	Voltage Code	Voltage	Min/Max Voltage	Compressor			HWG Pump FLA	EXT Loop Pump Fla	Total Unit FLA	Min Circuit Amps	Max Fuse/HACR
				QTY	RLA	LRA					
036	3	208-230/60/1	187/254	1	16.7	79	0.4	4	21.1	25.3	40
060	3	208-230/60/1	187/254	1	30.1	158	0.4	4	34.5	42.0	70
120	3	208-230/60/1	187/254	2	30.1	158	0.4	4	64.6	72.1	100

HACR circuit breaker in USA only
 Residential units come standard with 75VA transformer, HWG pump, and HWG connections

Electrical - Low Voltage

Changing FP1-Low Water Temperature Cutout Setpoint

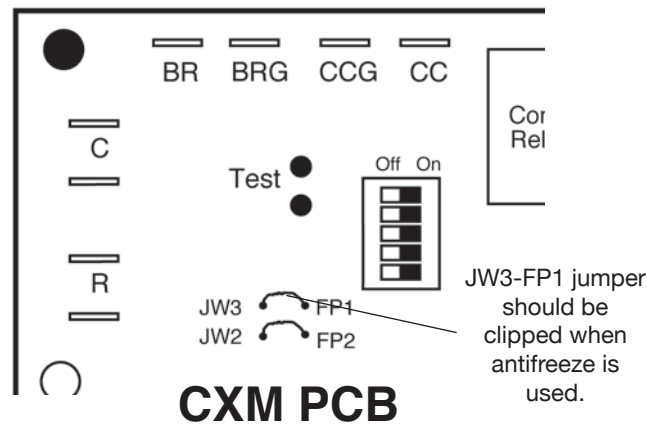

Low Water Temperature Cutout Selection

The CXM control allows the field selection of low water (or water-antifreeze solution) temperature limit by clipping jumper JW3, which changes the sensing temperature associated with thermistor FP1. Note that the FP1 thermistor is located on the refrigerant line between the coaxial heat exchanger and expansion device (TXV). Therefore, FP1 is sensing refrigerant temperature, not water temperature, which is a better indication of how water flow rate/temperature is affecting the refrigeration circuit.

The factory setting for FP1 is for systems using water (30°F [-1.1°C] refrigerant temperature). In low water temperature (extended range) applications with antifreeze (most ground loops), jumper JW3 should be clipped as shown in Figure 19 to change the setting to 10°F [-12.2°C] refrigerant temperature, a more suitable temperature when using an antifreeze solution. All residential units include water/refrigerant circuit insulation to prevent internal condensation, which is required when operating with entering water temperatures below 59°F [15°C].

Electrical - Low Voltage Wiring

Accessory Connections

A terminal paralleling the compressor contactor coil has been provided on the CXM control. Terminal "A" is designed to control accessory devices, such as water valves. Note: This terminal should be used only with 24 Volt signals and not line voltage. Terminal "A" is energized with the compressor contactor. See Figure 5 or the specific unit wiring diagram for details.

Figure 5: Accessory Wiring

Terminal Strip

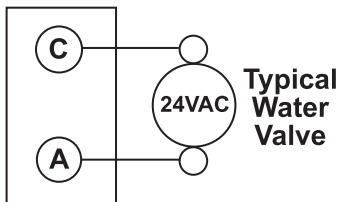

Water Solenoid Valves

An external solenoid valve(s) should be used on ground water installations to shut off flow to the unit when the compressor is not operating. A slow closing valve may be required to help reduce water hammer. Figure 5 shows typical wiring for a 24VAC external solenoid valve. Figures 6 or 7 illustrate typical slow closing water control valve wiring for Taco 500 series (ClimateMaster P/N AVM...) and Taco SBV series valves. Slow closing valves take approximately 60 seconds to open (very little water will flow before 45 seconds). Once fully open, an end switch allows the compressor to be energized. Only relay or triac based electronic thermostats should be used with slow closing valves. When wired as shown, the slow closing valve will operate properly with the following notations:

1. The valve will remain open during a unit lockout.
2. The valve will draw approximately 25-35 VA through the "Y" signal of the thermostat.

Note: This valve can overheat the anticipator of an electromechanical thermostat. Therefore, only relay or triac based thermostats should be used.

Figure 6: AVM Valve Wiring

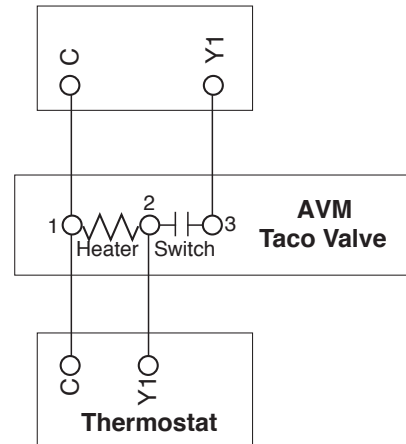
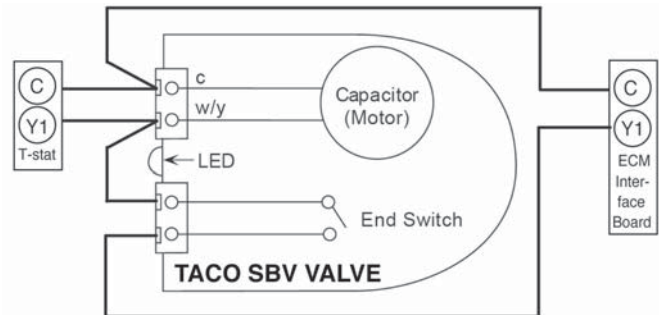
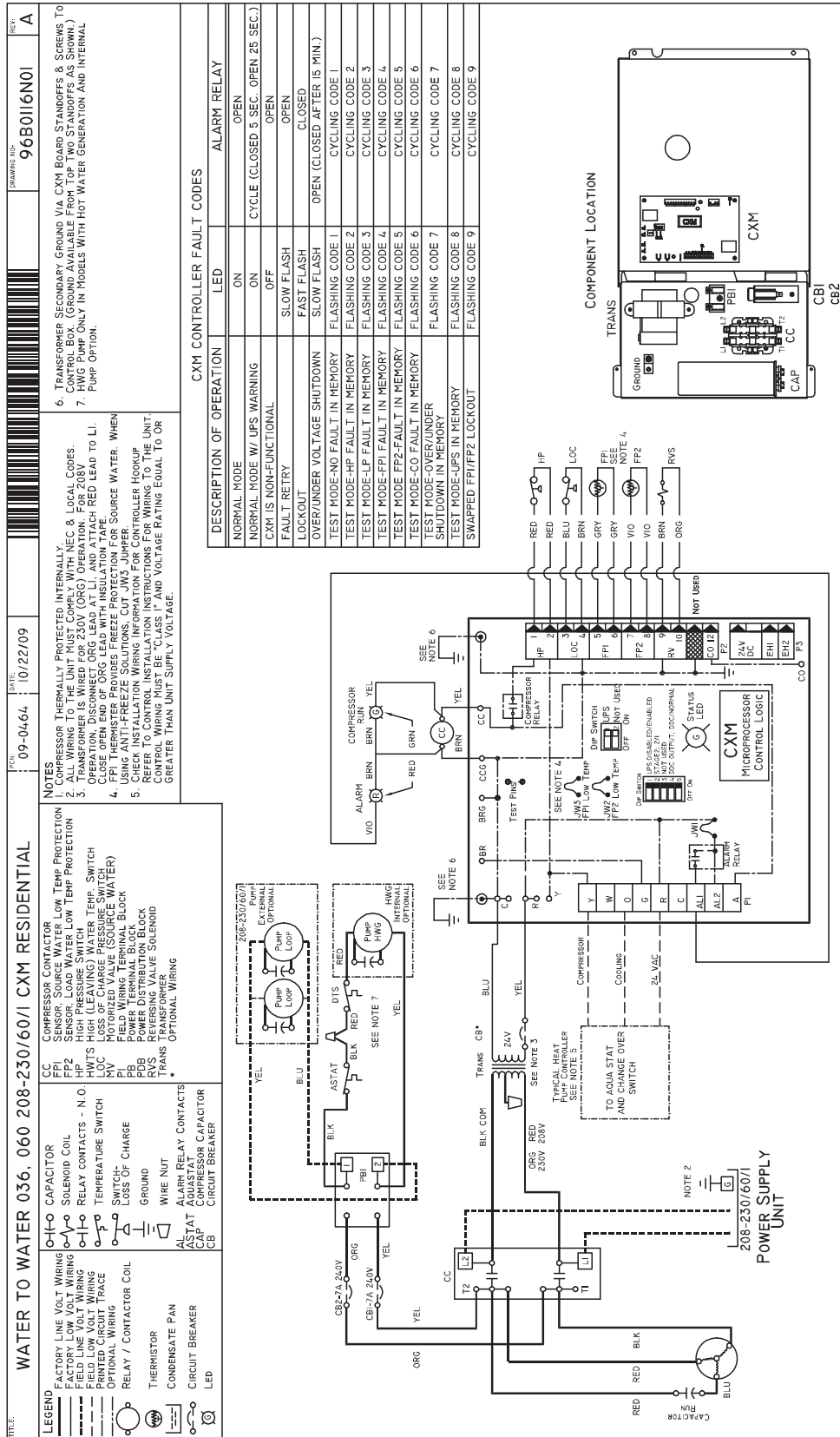

Figure 7: Taco SBV Valve Wiring



TMW036 & TMW060 Electrical Wiring Diagram - 96B0116N01



CXM Controls

CXM Control

For detailed control information, see the CXM Application, Operation and Maintenance (AOM) manual (part #97B0003N12).

Field Selectable Inputs

Test mode: Test mode allows the service technician to check the operation of the control in a timely manner. By momentarily shorting the test terminals, the CXM control enters a 20 minute test mode period in which all time delays are sped up 15 times. Upon entering test mode, the status LED will flash a code representing the last fault. For diagnostic ease at the thermostat, the alarm relay will also cycle during test mode. The alarm relay will cycle on and off similar to the status LED to indicate a code representing the last fault, at the thermostat. Test mode can be exited by shorting the test terminals for 3 seconds.

Retry Mode: If the control is attempting a retry of a fault, the status LED will slow flash (slow flash = one flash every 2 seconds) to indicate the control is in the process of retrying.

Field Configuration Options

Note: In the following field configuration options, jumper wires should be clipped ONLY when power is removed from the CXM control.

Water coil low temperature limit setting: Jumper 3 (JW3-FP1 Low Temp) provides field selection of temperature limit setting for FP1 of 30°F or 10°F [-1°F or -12°C] (refrigerant temperature).

Not Clipped = 30°F [-1°C]. Clipped = 10°F [-12°C].

Air coil low temperature limit setting: Jumper 2 (JW2-FP2 Low Temp) provides field selection of temperature limit setting for FP2 of 30°F or 10°F [-1°F or -12°C] (refrigerant temperature). Note: This jumper should only be clipped under extenuating circumstances, as recommended by the factory.

Not Clipped = 30°F [-1°C]. Clipped = 10°F [-12°C].

Alarm relay setting: Jumper 1 (JW1-AL2 Dry) provides field selection of the alarm relay terminal AL2 to be jumpered to 24VAC or to be a dry contact (no connection).

Not Clipped = AL2 connected to R. Clipped = AL2 dry contact (no connection).

DIP Switches

Note: In the following field configuration options, DIP switches should only be changed when power is removed from the CXM control.

DIP switch 1: Unit Performance Sentinel Disable - provides field selection to disable the UPS feature.

On = Enabled. Off = Disabled.

DIP switch 2: Stage 2 Selection - provides selection of whether compressor has an “on” delay. If set to stage 2, the compressor will have a 3 second delay before energizing. Also, if set for stage 2, the alarm relay will NOT cycle during test mode.

On = Stage 1. Off = Stage 2

DIP switch 3: Not Used.

DIP switch 4: DDC Output at EH2 - provides selection for DDC operation. If set to “DDC Output at EH2,” the EH2 terminal will continuously output the last fault code of the controller. If set to “EH2 normal,” EH2 will operate as standard electric heat output.

On = EH2 Normal. Off = DDC Output at EH2.

NOTE: Some CXM controls only have a 2 position DIP switch package. If this is the case, this option can be selected by clipping the jumper which is in position 4 of SW1.

Jumper not clipped = EH2 Normal. Jumper clipped = DDC Output at EH2.

DIP switch 5: Factory Setting - Normal position is “On.” Do not change selection unless instructed to do so by the factory.

Table 5a: CXM LED And Alarm Relay Operations

Description of Operation	LED	Alarm Relay
Normal Mode	On	Open
Normal Mode with UPS Warning	On	Cycle (closed 5 sec., Open 25 sec.)
CXM is non-functional	Off	Open
Fault Retry	Slow Flash	Open
Lockout	Fast Flash	Closed
Over/Under Voltage Shutdown	Slow Flash	Open (Closed after 15 minutes)
Test Mode - No fault in memory	Flashing Code 1	Cycling Code 1
Test Mode - HP Fault in memory	Flashing Code 2	Cycling Code 2
Test Mode - LP Fault in memory	Flashing Code 3	Cycling Code 3
Test Mode - FP1 Fault in memory	Flashing Code 4	Cycling Code 4
Test Mode - FP2 Fault in memory	Flashing Code 5	Cycling Code 5
Test Mode - CO Fault in memory	Flashing Code 6	Cycling Code 6
Test Mode - Over/Under shutdown in memory	Flashing Code 7	Cycling Code 7
Test Mode - UPS in memory	Flashing Code 8	Cycling Code 8
Test Mode - Swapped Thermistor	Flashing Code 9	Cycling Code 9

-Slow Flash = 1 flash every 2 seconds

-Fast Flash = 2 flashes every 1 second

-Flash code 2 = 2 quick flashes, 10 second pause, 2 quick flashes, 10 second pause, etc.

-On pulse 1/3 second; off pulse 1/3 second

Safety Features - CXM Controls

Safety Features – CXM Control

The safety features below are provided to protect the compressor, heat exchangers, wiring and other components from damage caused by operation outside of design conditions.

Anti-short cycle protection: The control features a 5 minute anti-short cycle protection for the compressor. Note: The 5 minute anti-short cycle also occurs at power up.

Random start: The control features a random start upon power up of 5-80 seconds.

Fault Retry: In Fault Retry mode, the Status LED begins slowly flashing to signal that the control is trying to recover from a fault input. The control will stage off the outputs and then “try again” to satisfy the thermostat input call. Once the thermostat input call is satisfied, the control will continue on as if no fault occurred. If 3 consecutive faults occur without satisfying the thermostat input call, the control will go into “lockout” mode. The last fault causing the lockout will be stored in memory and can be viewed at the “fault” LED (DXM board) or by going into test mode (CXM board). Note: FP1/FP2 faults are factory set at only one try.

Lockout: In lockout mode, the status LED will begin fast flashing. The compressor relay is turned off immediately. Lockout mode can be “soft” reset by turning off the thermostat (or satisfying the call). A “soft” reset keeps the fault in memory but resets the control. A “hard” reset (disconnecting power to the control) resets the control and erases fault memory.

Lockout with emergency heat: While in lockout mode, if W becomes active (CXM), emergency heat mode will occur. If DXM is configured for heat pump thermostat type (DIP 1.3), emergency heat will become active if O/W2 is energized.

High pressure switch: When the high pressure switch opens due to high refrigerant pressures, the compressor relay is de-energized immediately since the high pressure switch is in series with the compressor contactor coil. The high pressure fault recognition is immediate (does not delay for 30 continuous seconds before de-energizing the compressor).

High pressure lockout code = 2

Example: 2 quick flashes, 10 sec pause, 2 quick flashes, 10 sec. pause, etc.

Low pressure switch: The low pressure switch must be open and remain open for 30 continuous seconds during “on” cycle to be recognized as a low pressure fault. If the low pressure switch is open for 30 seconds prior to compressor power up it will be considered a low pressure (loss of charge) fault. The low pressure switch input is bypassed for the initial 120 seconds of a compressor run cycle.

Low pressure lockout code = 3

Water coil low temperature (FP1): The FP1 thermistor temperature must be below the selected low temperature limit setting for 30 continuous seconds during a compressor run cycle to be recognized as a FP1 fault. The FP1 input is bypassed for the initial 120 seconds of a compressor run cycle. FP1 is set at the factory for one try. Therefore, the control will go into lockout mode once the FP1 fault has occurred.

FP1 lockout code = 4

Air coil low temperature (FP2): The FP2 thermistor temperature must be below the selected low temperature limit setting for 30 continuous seconds during a compressor run cycle to be recognized as a FP2 fault. The FP2 input is bypassed for the initial 120 seconds of a compressor run cycle. FP2 is set at the factory for one try. Therefore, the control will go into lockout mode once the FP2 fault has occurred.

FP2 lockout code = 5

Condensate overflow: The condensate overflow sensor must sense overflow level for 30 continuous seconds to be recognized as a CO fault. Condensate overflow will be monitored at all times.

CO lockout code = 6

Over/under voltage shutdown: An over/under voltage condition exists when the control voltage is outside the range of 18VAC to 31.5VAC. Over/under voltage shutdown is a self-resetting safety. If the voltage comes back within range for at least 0.5 seconds, normal operation is restored. This is not considered a fault or lockout. If the CXM/DXM is in over/under voltage shutdown for 15 minutes, the alarm relay will close.

Over/under voltage shut down code = 7

Unit Performance Sentinel-UPS (patent pending):

The UPS feature indicates when the heat pump is operating inefficiently. A UPS condition exists when:

- a) In heating mode with compressor energized, FP2 is greater than 125°F [52°C] for 30 continuous seconds, or:
- b) In cooling mode with compressor energized, FP1 is greater than 125°F [52°C] for 30 continuous seconds, or:
- c) In cooling mode with compressor energized, FP2 is less than 40°F [4.5°C] for 30 continuous seconds.

If a UPS condition occurs, the control will immediately go to UPS warning. The status LED will remain on as if the control is in normal mode. Outputs of the control, excluding LED and alarm relay, will NOT be affected by UPS. The UPS condition cannot occur during a compressor off cycle. During UPS warning,

Safety Features

the alarm relay will cycle on and off. The cycle rate will be “on” for 5 seconds, “off” for 25 seconds, “on” for 5 seconds, “off” for 25 seconds, etc.

UPS warning code = 8

Swapped FP1/FP2 thermistors: During test mode, the control monitors to see if the FP1 and FP2 thermistors are in the appropriate places. If the control is in test mode, the control will lockout with code 9 after 30 seconds if:

- a) The compressor is on in the cooling mode and the FP1 sensor is colder than the FP2 sensor, or:
- b) The compressor is on in the heating mode and the FP2 sensor is colder than the FP1 sensor.

Swapped FP1/FP2 thermistor code = 9.

ESD (DXM only): The ESD (Emergency Shut Down) mode can be enabled from an external common signal to terminal ESD to shut down the unit. The green status light will flash code 3 when the unit is in ESD mode.

ESD mode = code 3 (green “status” LED)

CXM Controls

Diagnostic Features

The LED on the CXM board advises the technician of the current status of the CXM control. The LED can display either the current CXM mode or the last fault in memory if in test mode. If there is no fault in memory, the LED will flash Code 1 (when in test mode).

CXM Control Start-up Operation

The control will not operate until all inputs and safety controls are checked for normal conditions. The compressor will have a 5 minute anti-short cycle delay at power-up. The first time after power-up that there is a call for compressor, the compressor will follow a 5 to 80 second random start delay. After the random start delay and anti-short cycle delay, the compressor relay will be energized. On all subsequent compressor calls, the random start delay is omitted.

Unit Commissioning & Operating Conditions

Environment – This unit is designed for indoor installation only. Do not install in an area subject to freezing or where humidity levels can cause cabinet condensation.

Power Supply – A voltage variation of +/- 10% of nameplate utilization voltage is acceptable.

Operation and performance is primarily dependent upon water temperatures, water flow rates and ambient air temperature. This water to water heat pump is capable of operating over a wide temperature range and with flow rates of between 1.5 GPM (.1 l/s) and 3 GPM (.19 l/s) per ton, however usually no more than one of these factors may be at a minimum or maximum level at a time.

The commissioning table indicates water temperatures which are suitable for initial unit commissioning in an environment where the flow rate and water temperature is not yet stable and to avoid nuisance shut down of the units freeze and refrigerant pressure safeties.

The operating table indicates the maximum and minimum ranges of the unit.

For more specific unit performance reference the product catalog, the submittal data sheets or contact your supplier for assistance.

BUILDING COMMISSIONING						
	Cooling			Heating		
Unit Size	036	060/120	170/340	036	060/120	170/340
Source Min/Max	50/110	50/120	50/90	30/80	30/80	50/70
Load Min/Max	60/80	60/90	60/90	60/120	60/120	80/120
Ambient Min/Max	45/110			39/85		
BUILDING OPERATING						
	COOLING			HEATING		
Unit Size	036	060/120	170/340	036	060/120	170/340
Source Min/Max	50/120	50/120	50/110	20/80	20/80	20/70
Load Min/Max	50/90	50/90	50/90	60/130	60/130	60/120
Ambient Min/Max	45/110			39/85		

Unit & System Checkout

BEFORE POWERING SYSTEM, please check the following:

⚠ WARNING! ⚠

Verify ALL water controls are open and allow water flow prior to engaging the compressor. Freezing of the coax or water lines can permanently damage the heat pump.

NOTE: ClimateMaster strongly recommends all piping connections, both internal and external to the unit, be pressure tested by an appropriate method prior to any finishing of the interior space or before access to all connections is limited. Test pressure may not exceed the maximum allowable pressure for the unit and all components within the water system. ClimateMaster will not be responsible or liable for damages from water leaks due to inadequate or lack of a pressurized leak test, or damages caused by exceeding the maximum pressure rating during installation.

UNIT CHECKOUT

- ❑ **Balancing/Shutoff Valves:** Ensure all isolation valves are open, water control valves wired and open or coax may freeze and burst.
- ❑ **Line Voltage and Wiring:** Ensure Voltage is within an acceptable range for the unit and wiring and fuses/breakers are properly sized. Low voltage wiring is complete.
- ❑ **Unit Control Transformer:** Ensure transformer has properly selected control voltage tap. 208-230V units are factory wired for 230 operation unless specified otherwise.
- ❑ **Entering Water:** Ensure entering water temperatures are within operating limits of Table 5.
- ❑ **Low Water Temperature Cutout:** Verify low water temperature cut-out on CXM is properly set.
- ❑ **Water Flow Balancing:** Verify inlet and outlet water temperatures on both Load and source are recorded for each heat pump upon startup. This check can eliminate nuisance trip outs and high velocity water flows that can erode heat exchangers.
- ❑ **Unit Controls:** Verify CXM settings are proper and complete.

SYSTEM CHECKOUT

- ❑ **System Water Temperature:** Check load and source water temperature for proper range and also verify heating and cooling setpoints for proper operation.

- ❑ **System pH:** System water pH is 6 - 8.5. Proper pH promotes longevity of hoses and fittings.
- ❑ **System Flushing:** Verify all hoses are connected end to end when flushing to ensure debris bypasses unit heat exchanger and water valves etc. Water used in the system must be potable quality initially and clean of dirt, piping slag, and strong chemical cleaning agents. Verify all air is purged from the system. Air in the system can cause poor operation or system corrosion.
- ❑ **Cooling Tower/Boiler:** Check equipment for proper setpoints and operation.
- ❑ **Standby Pumps:** Verify the standby pump is properly installed and in operating condition.
- ❑ **System Controls:** Verify system controls function and operate in the proper sequence.
- ❑ **Low Water Temperature Cutout:** Verify low water temperature cut-out controls are provided for the outdoor portion of the loop or operating problems will occur.
- ❑ **System Control Center:** Verify control center and alarm panel for proper setpoints and operation.
- ❑ **Strainers:** Verify 20 mesh (841 micron) [0.84mm] strainers are installed in load and source water piping. Confirm maintenance schedule for strainers.
- ❑ **Miscellaneous:** Note any questionable aspects of the installation.

⚠ WARNING! ⚠

To avoid equipment damage, DO NOT leave system filled in a building without heat during the winter unless antifreeze is added to system water. Condenser coils never fully drain by themselves and will freeze unless winterized with antifreeze.

Figure 8: Test Mode Pins

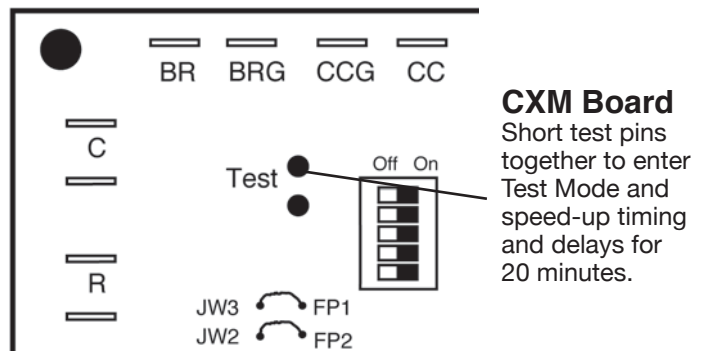

Unit Start Up Procedure

⚠ WARNING! ⚠

When the disconnect switch is closed, high voltage is present in some areas of the electrical panel. Exercise caution when working with energized equipment.

1. Adjust all valves to their full open position. Turn on the line power to all heat pump units.
2. Operate each unit in the cooling cycle.
3. Operate each heat pump in the heating cycle immediately after checking cooling cycle operation. A time delay will prevent the compressor from re-starting for approximately five (5) minutes.
4. Establish a permanent operating record by logging the unit operating conditions at initial start-up for each unit.
5. If a unit fails to operate, conduct the following checks:
 - a. Check the voltage and current. They should comply with the electrical specifications described on the unit nameplate.
 - b. Look for wiring errors. Check for loose terminal screws where wire connections have been made on both the line and low-voltage terminal boards.
 - c. Check the supply and return piping. They must be properly connected to the inlet and outlet connections on the unit.
 - d. If the checks described above fail to reveal the problem and the unit still will not operate, contact a trained service technician to ensure proper diagnosis and repair of the equipment.

Note: Units have a five minute time delay in the control circuit that can be eliminated on the CXM PCB as shown in Figure 8. See controls description for detailed features of the control.

⚠ WARNING! ⚠

Verify ALL water controls are open and allow water flow prior to engaging the compressor. Freezing of the coax or water lines can permanently damage the heat pump.

Water Temperature Change Through Source Heat Exchanger

Water Flow, gpm [l/m]	Rise, Cooling °F, [°C]	Drop, Heating °F, [°C]
For Closed Loop: Ground Source or Closed Loop Systems at 3 gpm per ton [3.9 l/m per kW]	9 - 12 [5 - 6.7]	4 - 8 [2.2 - 4.4]
For Open Loop: Ground Water Systems at 1.5 gpm per ton [2.0 l/m per kW]	20 - 26 [11.1 - 14.4]	10 - 17 [5.6 - 9.4]

Coax Water Pressure Drop TMW036-120

Model	GPM	Pressure Drop PSI			
		30°F	50°F	70°F	90°F
Source/Outdoor Coax					
036	4.5	1.7	1.3	1.0	0.8
	6.8	4.1	3.4	2.8	2.4
	9.0	7.1	6.0	5.1	4.5
060	7.5	1.5	1.3	1.1	0.9
	11.3	4.0	3.4	3.0	2.7
	15.0	6.9	6.2	5.5	5.0
120	15.0	1.7	1.4	1.2	0.9
	22.5	4.4	3.8	3.3	2.7
	30.0	7.6	6.8	6.1	5.0
Load/Outdoor Coax					
036	4.5		0.6	0.5	0.3
	6.8		1.4	1.3	1.1
	9.0		2.6	2.4	2.2
060	7.5		1.4	1.3	1.2
	11.3		3.5	3.2	3.0
	15.0		6.2	5.8	5.5
120	15.0		1.6	1.4	1.3
	22.5		3.8	3.5	3.3
	30.0		6.8	6.4	6.0

Must use antifreeze if operation falls in grey area

Operation not recommended

Multiply PSI x 2.31 to determine ft of hd

Operating Pressures

Operating Pressures

TMW036-120 (TMW120 Per Circuit) [60 Hz I.P. Units]								
Source Entering Water Temp °F	Source Water Flow GPM/ton	Cooling						
		Load EWT °F @ 1.5-3.0 GPM/Ton	Suction Pressure PSIG	Discharge Pressure PSIG	Super-heat	Sub-cooling	Water Temp Rise °F Source	Water Temp Drop °F Load
50	1.5	50	95-111	226-238	10-25	17-25	20-26	8-11
		60	106-126	235-247	10-25	17-25		
		70	118-141	247-258	10-25	17-25		
	2.3	50	89-105	210-222	11-29	14-21	15-19	11-15
		60	99-118	219-229	11-29	14-21		
		70	109-132	226-237	11-29	14-21		
	3.0	50	83-99	194-205	11-29	11-18	9-12	14-19
		60	91-111	200-210	11-29	11-18		
		70	100-122	205-216	11-29	11-18		
70	1.5	50	98-113	299-318	11-29	17-25	17-26	8-11
		60	113-130	310-333	11-29	17-25		
		70	128-147	321-349	11-29	17-25		
	2.3	50	93-113	283-300	9-21	14-22	15-19	12-15
		60	106-120	291-313	9-21	14-22		
		70	119-137	299-326	9-21	14-22		
	3.0	50	82-98	266-282	9-21	12-18	9-18	14-15
		60	91-111	272-292	9-21	12-18		
		70	100-122	278-303	9-21	12-18		
80	1.5	50	100-116	338-352	8-25	17-25	20-26	7-11
		60	117-136	350-365	8-25	17-25		
		70	134-156	362-377	8-25	17-25		
	2.3	50	94-110	319-334	8-25	15-21	18-22	7-15
		60	110-128	328-343	8-25	15-21		
		70	134-156	337-353	8-25	15-21		
	3.0	50	89-105	300-315	8-25	12-18	9-12	14-19
		60	103-120	307-322	8-25	12-18		
		70	117-136	313-328	8-25	12-18		
110	1.5	50	105-121	479-501	8-18	16-24	18-25	6-9
		60	124-140	490-515	8-18	16-24		
		70	142-159	501-529	8-18	16-24		
	2.3	50	100-116	459-482	8-18	14-24	13-18	8-13
		60	111-128	467-493	8-18	14-24		
		70	142-159	475-503	8-18	14-24		
	3.0	50	95-111	439-463	8-18	12-18	9-12	11-17
		60	111-128	444-470	8-18	12-18		
		70	135-152	450-477	8-18	12-18		
		80	140-162	455-482	8-18	12-18		

Operating Pressures

TMW036-120 (TMW120 Per Circuit) [60 Hz I.P. Units]								
Source Entering Water Temp °F	Source Water Flow GPM/ton	Heating						
		Load EWT °F @ 1.5-3.0 GPM/Ton	Suction Pressure PSIG	Discharge Pressure PSIG	Superheat	Sub-cooling	Water Temp Drop °F Source	Water Temp Rise °F Load
20	3.0	60	50-65	195-230	4-14	6-14	2-6	4-14
		80	50-65	280-300	4-14	6-14		4-14
		90	55-70	300-350	4-14	6-14		4-14
		100	55-70	350-390	4-14	6-14		4-14
		120	60-78	450-510	4-14	6-14		4-14
30*	1.5	60	50-70	190-230	5-12	5-9	5-13	3-13
		80	50-70	280-305	5-12	5-9		3-13
		90	55-70	300-350	5-12	5-9		3-13
		100	55-70	350-390	5-12	5-9		3-13
		120	60-80	450-515	5-12	5-9		3-13
	2.3	60	65-80	205-240	5-13	6-9	4-11	3-14
		80	65-80	290-330	5-13	6-9		3-14
		90	70-85	330-375	5-13	6-9		3-14
		100	70-85	380-430	5-13	6-9		3-14
		120	70-85	465-520	5-13	6-9		3-14
	3.0	60	70-80	200-245	5-14	6-9	3-8	3-15
		80	75-90	290-315	5-14	6-9		3-15
90		75-90	310-365	5-14	6-9	3-15		
100		75-90	370-405	5-14	6-9	3-15		
120		80-90	460-520	5-14	6-9	3-15		
50	1.5	60	80-100	205-230	6-11	7-11	9-16	4-17
		80	85-105	280-320	6-11	7-11		4-17
		90	90-105	320-340	6-11	7-11		4-17
		100	90-105	370-400	6-11	7-11		4-17
		120	100-115	470-490	6-11	7-11		4-17
	2.3	60	90-105	210-230	6-13	7-11	6-12	5-18
		80	95-120	300-320	6-13	7-11		5-18
		90	95-120	325-350	6-13	7-11		5-18
		100	100-115	380-410	6-13	7-11		5-18
		120	105-120	470-500	6-13	7-11		5-18
	3.0	60	90-110	210-260	6-14	7-15	5-9	5-19
		80	100-115	300-330	6-14	7-15		5-19
90		100-115	320-380	6-14	7-15	5-19		
100		100-120	390-420	6-14	7-15	5-19		
120		100-120	470-530	6-14	7-15	5-19		
70	1.5	60	90-115	215-235	9-17	6-12	12-19	6-20
		80	100-125	295-325	9-17	6-12		6-20
		90	110-125	330-350	9-17	6-12		6-20
		100	110-130	385-410	9-17	6-12		6-20
		120	125-140	480-500	9-17	6-12		6-20
	2.3	60	110-120	215-235	9-20	6-12	8-14	6-20
		80	120-135	305-325	9-20	6-12		6-20
		90	125-140	330-355	9-20	6-12		6-20
		100	125-140	390-415	9-20	6-12		6-20
		120	135-145	480-505	9-20	6-12		6-20
	3.0	60	110-130	215-270	12-25	6-12	6-11	8-20
		80	115-135	290-335	12-25	6-12		8-20
90		120-145	330-395	12-25	6-12	8-20		
100		120-145	395-420	12-25	6-12	8-20		
120		130-150	480-545	12-25	6-12	8-20		

*Based on 15% methanol antifreeze solution

Preventative Maintenance

Water Coil Maintenance

(Direct ground water applications only) - If the system is installed in an area with a known high mineral content (125 P.P.M. or greater) in the water, it is best to establish a periodic maintenance schedule with the owner so the coil can be checked regularly. Consult the well water applications section of this manual for a more detailed water coil material selection. Should periodic coil cleaning be necessary, use standard coil cleaning procedures, which are compatible with the heat exchanger material and copper water lines. Generally, the more water flowing through the unit, the less chance for scaling. Therefore, 1.5 gpm per ton [2.0 l/m per kW] is recommended as a minimum flow. Minimum flow rate for entering water temperatures below 50°F [10°C] is 2.0 gpm per ton [2.6 l/m per kW].

Water Coil Maintenance

(All other water loop applications)
Generally water coil maintenance is not needed for closed loop systems. However, if the piping is known to have high dirt or debris content, it is best to establish a periodic maintenance schedule with the owner so the water coil can be checked regularly. Dirty installations are typically the result of deterioration of iron or galvanized piping or components in the system. Open cooling towers requiring heavy chemical treatment and mineral buildup through water use can also contribute to higher maintenance. Should periodic coil cleaning be necessary, use standard coil cleaning procedures, which are compatible with both the heat exchanger material and copper water lines. Generally, the more water flowing through the unit, the less chance for scaling. However, flow rates over 3 gpm per ton (3.9 l/m per kW) can produce water (or debris) velocities that can erode the heat exchanger wall and ultimately produce leaks.

Hot Water Generator Coils

See water coil maintenance for ground water units. If the potable water is hard or not chemically softened, the high temperatures of the desuperheater will tend to scale even quicker than the water coil and may need more frequent inspections. In areas with extremely hard water, a HWG is not recommended.

Compressors

Conduct annual amperage checks to ensure amp draw is no more than 10% greater than that indicated by serial plate data.

Cabinet

Do not allow water to stay in contact with the cabinet for long periods of time to prevent corrosion of the cabinet sheet metal. Generally vertical cabinets are set up from the floor a few inches for prevention. The cabinet can be cleaned using a mild detergent.

Refrigerant System

To maintain sealed circuit integrity, do not install service gauges unless unit operation appears abnormal. Reference the operating chart for pressure and temperatures. Verify that air and water flow rates are at proper levels before servicing the refrigerant circuit.

If the refrigerant circuit is opened for any reason, a new liquid line filter-drier must be installed.

Refrigeration Troubleshooting Form

Water-to-Water Units

Customer: _____ Loop Type: _____ Startup Date: _____
 Model #: _____ Serial #: _____ Antifreeze Type & %: _____
 Complaint: _____

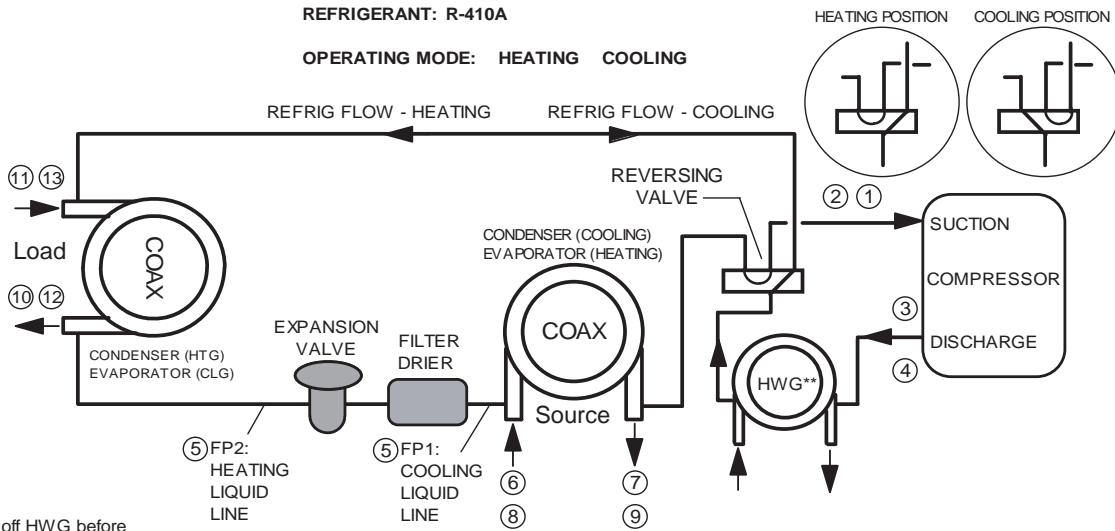

Description	Heating	Cooling	Notes
1			
2			
2a			
2b			
3			
4			
4a			
4b			
5			
6			
7			Temp Diff. =
8			
9			
9a			
9b			
10			<--Water-to-Water units only
11			Temp Diff. =
12			<--Water-to-Water units only
13			<--Water-to-Water units only
13a			<--Water-to-Water units only
13b			<--Water-to-Water units only

Heat of Extraction (Absorption) or Heat of Rejection:

Fluid Factor: (for Btuh)
 500 (Water); 485 (Antifreeze)

Fluid Factor: (for kW)
 4.18 (Water); 4.05 (Antifreeze)

HE or HR =

_____ Flow Rate x _____ Temp. Diff x _____ Fluid Factor

Warranty



CLIMATE MASTER, INC. LIMITED EXPRESS WARRANTY/LIMITATION OF REMEDIES AND LIABILITY FOR RESIDENTIAL CLASS PRODUCTS WITH LABOR ALLOWANCE

It is expressly understood that unless a statement is specifically identified as a warranty, statements made by Climate Master, Inc. a Delaware corporation, ("CM") or its representatives, relating to CM's products, whether oral, written or contained in any sales literature, catalog or agreement, are not express warranties and do not form a part of the basis of the bargain, but are merely CM's opinion or commendation of CM's products. **EXCEPT AS SPECIFICALLY SET FORTH HEREIN, THERE IS NO EXPRESS WARRANTY AS TO ANY OF CM'S PRODUCTS. CM MAKES NO WARRANTY AGAINST LATENT DEFECTS. CM MAKES NO WARRANTY OF MERCHANTABILITY OF THE GOODS OR OF THE FITNESS OF THE GOODS FOR ANY PARTICULAR PURPOSES.**

GRANT OF LIMITED EXPRESS WARRANTY

CM warrants its Residential Class products, purchased and retained in the United States of America and Canada, to be free from defects in material and workmanship under normal use and maintenance as follows: (1) Air conditioning, heating and/or heat pump units built or sold by CM ("CM Units") for five (5) years from the Warranty Inception Date (as defined below); (2) Thermostats, auxiliary electric heaters and geothermal pumping modules built or sold by CM, when installed with CM Units, for five (5) years from the Warranty Inception Date (as defined below); (3) Sealed refrigerant circuit components of CM Units (which components only include the compressor, refrigerant to air/water heat exchangers, reversing valve body and refrigerant metering device) for ten (10) years from the Warranty Inception Date (as defined below); and (4) Other accessories and parts built or sold by CM, when installed with CM Units, for one (1) year from the date of shipment from CM. The "Warranty Inception Date" shall be the date of original unit installation, or six (6) months from date of unit shipment from CM, whichever comes first.

To make a claim under this warranty, parts must be returned to CM in Oklahoma City, Oklahoma, freight prepaid, no later than ninety (90) days after the date of the failure of the part; if CM determines the part to be defective and within CM's Limited Express Warranty, CM shall, when such part has been either replaced or repaired, return such to a factory recognized distributor, dealer or service organization, F.O.B. CM, Oklahoma City, Oklahoma. The warranty on any part repaired or replaced under warranty expires at the end of the original warranty period.

This Limited Express Warranty shall cover the labor incurred by CM authorized service personnel in connection with the installation of a new or repaired warranty part that is covered by this Limited Express Warranty only to the extent specifically set forth in the then existing labor allowance schedule provided by CM's Warranty Department and only as follows: (1) CM Units for two (2) years from the Warranty Inception Date; (2) Thermostats, auxiliary electric heaters and geothermal pumping modules built or sold by CM, when installed with CM Units, for two (2) years from the Warranty Inception Date; and (3) Sealed refrigerant circuit components of CM Units (which components only include the compressor, refrigerant to air/water heat exchangers, reversing valve body and refrigerant metering device) for five (5) years from the Warranty Inception Date. Actual Labor costs are not covered by this Limited Express Warranty to the extent they exceed the amount allowed under said allowance schedule; they are not specifically provided for in said allowance schedule; they are not the result of work performed by CM authorized service personnel; they are incurred in connection with a part not covered by this Limited Express Warranty; or they are incurred more than the time periods set forth in this paragraph after the Warranty Inception Date.

This warranty does not cover and does not apply to: (1) Air filters, fuses, refrigerant, fluids, oil; (2) Products relocated after initial installation; (3) Any portion or component of any system that is not supplied by CM, regardless of the cause of the failure of such portion or component; (4) Products on which the unit identification tags or labels have been removed or detached; (5) Products on which payment to CM, or to the owner's seller or installing contractor, is in default; (6) Products subjected to improper or inadequate installation, maintenance, repair, wiring or voltage conditions; (7) Products subjected to accident, misuse, negligence, abuse, fire, flood, lightning, unauthorized alteration, misapplication, contaminated or corrosive air or liquid supply, operation at abnormal air or liquid temperatures or flow rates, or opening of the refrigerant circuit by unqualified personnel; (8) Mold, fungus or bacteria damage; (9) Corrosion or abrasion of the product; (10) Products supplied by others; (11) Products which have been operated in a manner contrary to CM's printed instructions; (12) Products which have insufficient performance as a result of improper system design or improper application, installation, or use of CM's products; or (13) Electricity or fuel costs, or any increases or unrealized savings in same, for any reason whatsoever.

Except for the limited labor allowance coverage set forth above, CM is not responsible for: (1) The costs of any fluids, refrigerant or system components supplied by others, or associated labor to repair or replace the same, which is incurred as a result of a defective part covered by CM's Limited Express Warranty; (2) The costs of labor, refrigerant, materials or service incurred in diagnosis and removal of the defective part, or in obtaining and replacing the new or repaired part; (3) Transportation costs of the defective part from the installation site to CM, or of the return of that part if not covered by CM's Limited Express Warranty; or (4) The costs of normal maintenance.

This Limited Express Warranty applies to CM Residential Class products manufactured on or after January 1, 2009 (i.e. CM Units with serial numbers beginning with "W" and higher) and is not retroactive to any products manufactured prior to January 1, 2009 (i.e. CM Units with serial numbers beginning with "L" and lower).

Limitation: This Limited Express Warranty is given in lieu of all other warranties. If, notwithstanding the disclaimers contained herein, it is determined that other warranties exist, any such express warranty, including without limitation any express warranties or any implied warranties of fitness for particular purpose and merchantability, shall be limited to the duration of the Limited Express Warranty.

LIMITATION OF REMEDIES

In the event of a breach of the Limited Express Warranty, CM will only be obligated at CM's option to repair the failed part or unit, or to furnish a new or rebuilt part or unit in exchange for the part or unit which has failed. If after written notice to CM's factory in Oklahoma City, Oklahoma of each defect, malfunction or other failure, and a reasonable number of attempts by CM to correct the defect, malfunction or other failure, and the remedy fails or is essential purpose, CM shall refund the purchase price paid to CM in exchange for the return of the sold good(s). Said refund shall be the maximum liability of CM. **THIS REMEDY IS THE SOLE AND EXCLUSIVE REMEDY OF THE BUYER OR PURCHASER AGAINST CM FOR BREACH OF CONTRACT, FOR THE BREACH OF ANY WARRANTY OR FOR CM'S NEGLIGENCE OR IN STRICT LIABILITY.**

LIMITATION OF LIABILITY

CM shall have no liability for any damages if CM's performance is delayed for any reason or is prevented to any extent by any event such as, but not limited to, any war, civil unrest, government restrictions or restraints, strikes, or work stoppages, fire, flood, accident, shortages of transportation, theft, material or labor, acts of God or any other reason beyond the sole control of CM. **CM EXPRESSLY DISCLAIMS AND EXCLUDES ANY LIABILITY FOR CONSEQUENTIAL, OR INCIDENTAL, DAMAGE IN CONTRACT, FOR BREACH OR ANY EXPRESS OR IMPLIED WARRANTY, OR IN TORT, WHETHER FOR CM'S NEGLIGENCE OR AS STRICT LIABILITY.**

OBTAINING WARRANTY PERFORMANCE

Normally, the dealer or service organization who installed the products will provide warranty performance for the owner. Should the installer be unavailable, contact any CM recognized distributor, dealer or service organization. If assistance is required in obtaining warranty performance, write or call:

Climate Master, Inc. • Customer Service • 7300 SW 44th Street • Oklahoma City, Oklahoma 73179 • (405) 745-6000 • e-service@climatemaster.com

NOTE: Some states or Canadian provinces do not allow limitations on how long an implied warranty lasts, or the limitation or exclusions of consequential or incidental damages, so the foregoing exclusions and limitations may not apply to you. This warranty gives you specific legal rights, and you may also have other rights which vary from state to state and from Canadian province to Canadian province.

Please refer to the CM Installation, Operation and Maintenance Manual for operating and maintenance instructions.

Rev.: 3/09
Part No.: R410A

Revision History

Date:	Item:	Action:
10/30/09	Functional Troubleshooting Table	Updated
09/15/09	Safety Features - CXM/DXM Controls	Updated
06/01/09	Operating Pressures Heating Table	Updated
05/07/09	'Unit Starting & Operating Conditions' Section & Table	Edited and renamed 'Unit Commissioning and Operating Conditions'
04/16/09	First Published	



97B0068N01

97B0068N01

35 Earl Martin Drive
 Elmira, ON N3B 3L4
 Tel: 800-367-9810
www.nextenergy.ca

ClimateMaster works continually to improve its products. As a result, the design and specifications of each product at the time for order may be changed without notice and may not be as described herein. Please contact ClimateMaster's Customer Service Department at 1-405-745-6000 for specific information on the current design and specifications. Statements and other information contained herein are not express warranties and do not form the basis of any bargain between the parties, but are merely ClimateMaster's opinion or commendation of its products.

The management system governing the manufacture of ClimateMaster's products is ISO 9001:2000 certified.